

TurboCharger™
(For T80 & T80HV models)
Installation and Operation Manual



23 Francis J. Clarke Circle, Bethel, CT 06801 USA
(203) 790-6400
www.ApolloSolar.com

TABLE OF CONTENTS

Revision History	2
Important Safety Instructions.....	3
Overview	4
Theory of Operation	5
Planning Your System.....	6
Loads	6
Determining Battery Voltage.....	6
Determining PV Array Voltage.....	7
Maximum Voc.....	7
Conversion Efficiency	8
Wire Sizing	8
Determining Maximum Current.....	9
Circuit Protection	9
Lightning Protection.....	10
Installation	11
Initialization	14
Front Panel LED Status Indicator	18
Restarting the TurboCharger™	18
Operating the TurboCharger™	19
Status Screens	19
Data Screens.....	20
Setup	21
Setup Selections Screen	22
Main EQ Setup Screen.....	23
Main Miscellaneous Setup Screen	25
Aux Relay Setup Screen	28
Emonitor Setup Screen	32
Wiring Diagram with Batteries	33
Networking (Stacking) Multiple TurboChargers™	34
Warranty Information.....	37
Appendix A – Wire Sizing Table for 1.5% Voltage Drop.....	38
Appendix B – Bootloader Function.....	44

Revision History

Manual Revision	Applies to Firmware Revision	Date	BY
1.7	3.20	12/12/06	KMV
1.8	3.20, 4.00, 4.03	4/24/07	KMV
1.9	3.20, 4.00, 4.03, 4.04, 5.00	6/29/07	KMV
1.91	5.00	7/16/07	KMV
2.0	5.04	7/23/07	KMV
2.1	6.03	10/19/07	KMV
2.11	6.06	1/31/08	KMV
3.0	6.10, 6.11	3/27/08	KMV
3.1	7.08, 7.09, 7.10	7/21/09	HF
3.2	7.08, 7.09, 7.10	11/12/09	KMV
3.3	7.17	2/9/10	HF
3.4	7.18	3/1/10	HF
3.5	8.00	8/1/2010	JS
3.6	8.00	12/17/10	HF
3.7	8.00	4/7/11	HF

IMPORTANT SAFETY INSTRUCTIONS

SAVE THESE INSTRUCTIONS

The TurboCharger™ is capable of processing over 4.8 kW of DC power. These Safety Instructions are to ensure safe installation and operation of the TurboCharger™ and the equipment it is connected to. Be sure to read the instructions which came with the TurboCharger™ and all other connected equipment carefully. Inspect the TurboCharger™ and all other equipment and read all cautionary and instructive markings on all equipment. Be sure to follow all cautions and instructions when installing all equipment. Save this manual, it has important maintenance and operation information.

The TurboCharger™ Battery System Controller is designed to be permanently connected to a DC electrical system. The TurboCharger™ must be provided with an equipment-grounding conductor connected to the DC input ground.

THIS IS THE SYMBOL FOR GROUND: 

- ⇒ Use a minimum of #8 AWG conductors rated for at least 75° C.
- ⇒ The input/output and ground terminals on the TurboCharger™ will accept #8 to #3 AWG wire. The lugs are rated to accept a single conductor.
- ⇒ Torque all connections to 50 lb-in (5.65 N-m)

Apollo Solar recommends that all wiring be done by an electrician or certified technician in accordance to all local and national electrical codes applicable in your jurisdiction. Do not perform electrical work you do not feel qualified to do.

To avoid a risk of fire and electric shock, make sure that existing wiring is in good condition and that wire is not undersized. Do not operate the TurboCharger™ or any other system components with damaged or substandard wiring. Use only attachments recommended or sold by Apollo Solar or our Authorized Distribution Partners, doing otherwise may result in a risk of fire, electric shock, or injury to persons. To reduce the risk of electrical shock, disconnect all sources of DC power from the TurboCharger™ before attempting any maintenance or cleaning or working on any components connected to the controller.

INTENDED USE

The TurboCharger™ is designed to charge lead acid batteries of flooded, gel and AGM chemistries from 12 to 48 Vdc nominal. For all other battery types follow specific voltage, current, and time settings provided by the manufacturer of the batteries.

WARNING

The TurboCharger™ is designed for use in a controlled environment (i.e. for indoor use only). Do not expose this unit to rain, snow, or liquids of any type. Damp environments will significantly shorten the life of this product and installation in damp environments may affect the product warranty. (For information about damp environment warranty exclusions see the Warranty section at the end of this manual).

Do not operate the TurboCharger™ if it has been damaged in any way. If the unit is damaged follow the product return directions in the Warranty section at the end of this manual. Do not disassemble the TurboCharger™. The TurboCharger™ does not have any user-serviceable parts. Internal capacitors remain charged after all power is disconnected and attempting to service the unit may result in a risk of electrical shock or fire. Always use insulated tools to reduce the chance of short-circuits when installing or working with the TurboCharger™, the batteries, PV arrays and any other connected equipment. To further reduce the risk of exposure to live circuits remove all jewelry while installing this system. A battery can present a risk of electrical shock, burn from high short circuit current, fire or explosion from vented gas. Observe proper precautions.

EXPLOSIVE GAS PRECAUTIONS

Working in the vicinity of lead acid batteries is dangerous. Batteries generate explosive gases during normal operation. Follow all Explosive Gas Safety procedures. To reduce the risk of battery explosion, follow these instructions and those published by the battery manufacturer and supplier.

Proper Disposal of Batteries is required. Refer to your local codes for disposal requirements.

OVERVIEW

The Apollo TurboCharger™ is essentially a smart DC to DC converter which has been optimized to harvest maximum energy from the PV array in battery based solar electric systems by using a variety of maximum power point tracking (MPPT) strategies. The controller's secondary objective is to ensure that the batteries receive a full charge without becoming overcharged. This is accomplished through a five stage charging process. Built into the unit is a comprehensive data logging system which tracks battery state of charge (SOC) and power produced by the PV array.

The DC to DC converter feature allows for a wide variety of input and battery voltage configurations. Batteries may be configured from 12 to 48 Vdc nominal (12, 24, 36, and 48 are the factory default settings). This feature allows system designers considerable flexibility with respect to wire sizing and module location. At this time there are 2 models of the TurboCharger the T80 and the T80HV. The two models operate exactly the same with only one difference, the maximum input voltage. For the T80 the PV arrays may be wired in up to 112 Vdc nominal, with the actual constraint being the maximum allowable Voc at worse case conditions, 150 Voc. (The T80 automatically shuts down above 140 Voc.) For the T80HV the PV arrays can be wired in up to 160 Vdc nominal, with the actual constraint being the maximum allowable Voc at worse case conditions, 200 Voc. (The T80HV automatically shuts down above 180 Voc.) **The T80HV model is not recommended for 12V systems, the T80 version should be considered instead (see “Determining Battery Voltage” below).**

The TurboCharger™ features two auxiliary relays. These relays have a host of control uses and functions and can be custom programmed to suit the system operator's needs (refer to the Aux relay setup screen section of operating instructions for more information).

Please carefully read the *Planning Your System* section of this manual and all warnings before beginning your installation. To ensure best performance follow all installation instructions and wiring guidelines. Always install equipment in accordance to local codes and bylaws. We recommend that external lightning protection be installed along with the TurboCharger™.

THEORY OF OPERATION

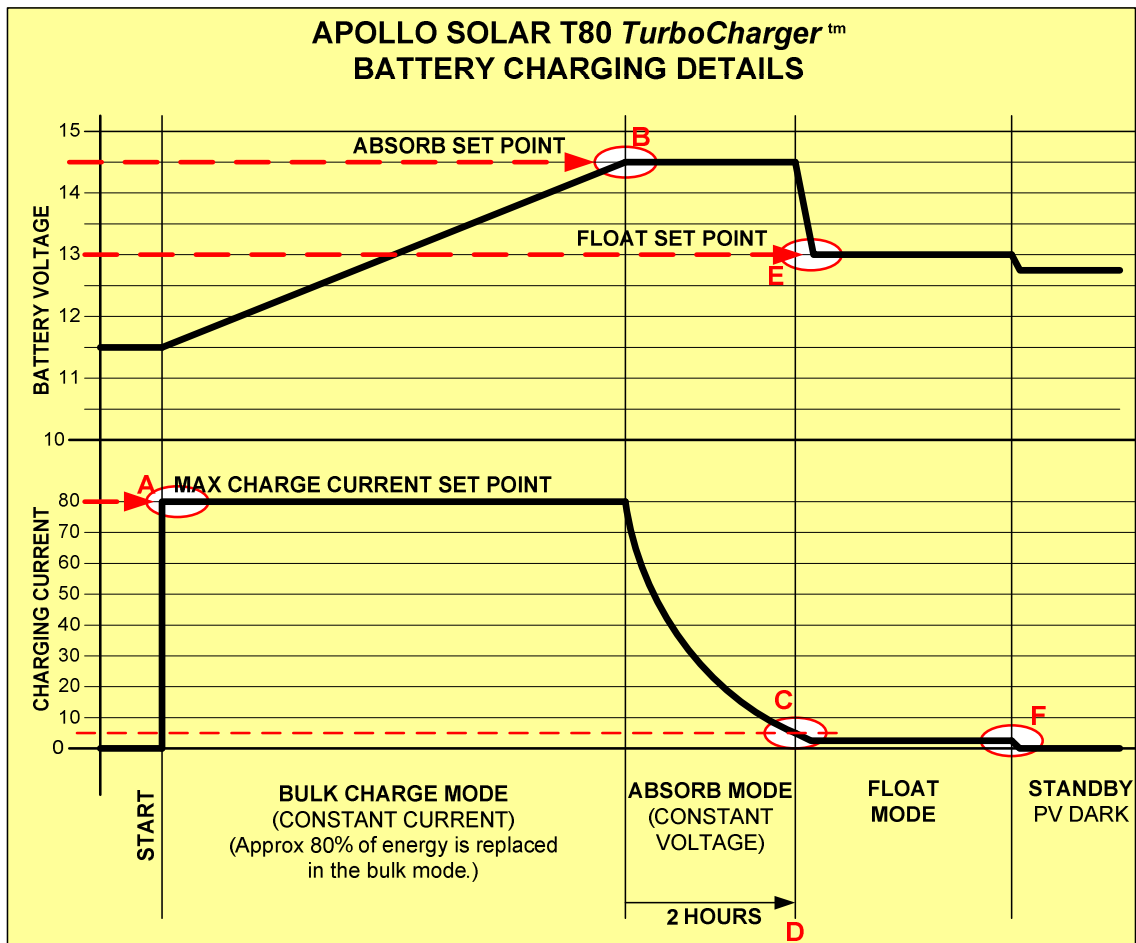

Bulk: In the Bulk Mode the Controller is trying to get the battery voltage up to the Absorb Voltage Setting (B). It will use all the power it can get from the panels limited only by the Maximum Charge setting (A). When the Absorb Voltage is reached on the batteries, the charger switches into Absorb Mode.

Absorb: In this mode the Charger will supply just enough current to maintain the Absorb Voltage setting. This current will gradually decrease over time with a constant load but can vary due to outside loads. The charger stays in absorb until the Absorb Timer counts down to 0 or for as long as the batteries were in Bulk Mode that day which ever time is shorter. The timer is suspended if the Battery Voltage drops 1 V below the Absorb Voltage Setting due to loading. When the Timer counts down to 0 the Charger goes into Float Mode (D). At this point, the Charger will output a minimum current (C), unless a load requires more.

Float: When first switching to this mode the Charger may experience a short period of 0 Amps output. This is because the Absorb Voltage is usually set higher than the Float Voltage and the controller waits for the battery voltage to drop. In this mode the Charger will supply just enough current (F) to maintain the Float Voltage setting (E). The current required to maintain the battery at this voltage is usually fairly small but as loads are applied the current will rise to try to maintain the voltage level.

Standby: The Charger will go into the Standby mode whenever the PV Voltage applied to the input is less than the Battery Voltage on the output +10%. Example: If the Battery Voltage = 49.0V then the PV Voltage must be at least 53.9V or the unit will stop charging and go into Standby Mode.

PLANNING YOUR SYSTEM

Loads

Congratulations on choosing a solar electric system, when designed and installed properly it should give you decades of service life. The TurboCharger™ is a key component in your PV system. From a system planners perspective it is very flexible with the ability to accept a wide range of input voltages and produce a similarly wide range of output voltages. Never-the-less some planning and choice is required when deciding on the components and configuration of your PV system.

The first step in planning a PV system is to know something about the load. What is the power intended for? How much power will be required? There are many resources available in print and on-line to help determine average and peak load requirements we recommend using these resources to calculate anticipated load requirements. We also recommend that planners design for load growth. Experience has shown that loads rarely remain static and are reduced even less frequently. Once the load characteristics are determined the system planner may move to make decisions about the appropriate battery voltage.

Determining Battery Voltage

A major factor in making this decision is how much power will be required from the batteries. As power demands increase it is advisable to raise the battery voltage. A limiting factor in system design is current – it is expensive to move and provide circuit protection for large amounts of current (amps). A basic rule of electricity states “current = power/voltage”. This means that the higher the battery voltage the lower the current will be for any given load. For example a 96 watt load at 12 Volts draws 8 amps the same load at 48 Volts draws only 2 amps of current.

The table below shows rule-of-thumb recommendations for battery system voltage choices and maximum inverter sizes.

Load in kWh per day	Battery Voltage	Suggested Inverter Size
Under 2 kWh per day	12 Vdc	Up to 2.5 kW
2 to 6 kWh per day	24 Vdc	2-4 kW
Over 6 kWh per day	48 Vdc	3 kW and larger

Other factors in making this decision will include the size of the inverter.

A final factor in this decision is how much power will be required from the PV array. The TurboCharger™ is designed to produce 80 amps of output current. The amount of power this represents will be dependent on the output voltage (battery bank voltage). At 12 Vdc output 80 amps is 960 watts of power, at 48 Vdc output 80 amps is 3840 watts of power. The example above demonstrates that the amount of current or input power the TurboCharger™ will accept is limited by the system battery voltage.

Note: Although it supports 12V, the T80HV is not recommended for 12V systems, the T80 should be considered instead as it is more efficient in 12V applications.

Determining PV Array Voltage

One of the great advantages of the DC to DC converter design of the TurboCharger™ is that PV array voltages are no longer dictated by the battery voltage. Sizing a PV array for the is much like sizing a grid-tie inverter, the same questions apply: What is the max and min Vmp and Voc of each string, how many strings will be needed.

Sellback Operation

When used in a system with a grid connected inverter. Set the sellback voltage on the inverter to just below the absorb voltage setting. This will ensure that the TurboCharger™ will deliver full current from the PV array. It is advised that sellback be turned off occasionally to allow the batteries to float.

Maximum Voc

Each PV module has specific ratings for voltage and current at standard test conditions and temperatures, the manufacturers also publish current and temperature coefficients. The Voc for any PV module increases in cold temperatures. Modules are rated with an assumed cell temperature of 25° C, when calculated at 0° C there may be as much as a 25% increase in the rated Voc. The Voc voltage temperature coefficient for the specific location of the installation must be calculated from known weather data. Once the maximum Voc of the module is found a series string voltage may be determined.

T80 model: The maximum operating voltage of the T80 is 140 Vdc. Above this, the unit will shut down to avoid damage. The absolute maximum applied input voltage the controller can accept without damage is 150 Vdc.

WARNING

The Voc maximum on the coldest brightest day of the year must not exceed 150 Vdc for the T80. Input voltage in excess of 150 Vdc will result in internal damage which is NOT covered by warranty. We recommend a maximum design Voc of 140 Vdc. This will result in the most effective energy harvest.

T80HV model: The maximum operating voltage of the T80HV is 180 Vdc. Above this, the unit will shut down to avoid damage. The absolute maximum applied input voltage the controller can accept without damage is 200 Vdc.

WARNING

The Voc maximum on the coldest brightest day of the year must not exceed 200 Vdc for the T80HV. Input voltage in excess of 200 Vdc will result in internal damage which is NOT covered by warranty. We recommend a maximum design Voc of 180 Vdc. This will result in the most effective energy harvest.

Conversion Efficiency

The conversion efficiency of the TurboCharger™ in the proposed configuration must be considered. While it is possible to input 72 Vdc and output 12 Vdc, it is not the most efficient configuration for the controller. A system which had 36 Vdc input and 12 Vdc output would run more efficiently from the T80HV's perspective. The most efficient configuration is with 60 Vdc input and 48 Vdc output. Nevertheless, in many cases the savings in wire costs and the slight advantage of earlier wake up and shut down make the "inefficient" higher voltage to low voltage conversion the best system choice. Many systems input 72 Vdc for 24 and 48 Vdc batteries. The table below shows some recommended input to output configurations for a system using the T80 model.

Battery Voltage	Array Vmp Range
12 Vdc	16 - 83 Vdc
24 Vdc	32 – 136 Vdc
48 Vdc	70 – 150 Vdc*

* Never exceed 140 Voc in any T80 system design.

Wire Sizing

The distance between the PV array and the controller will be a factor in choosing an optimum string voltage for the TurboCharger™. The higher the input voltage the smaller the wire can be for any given amount of power. For example a system with a 12 volt battery and a PV array consisting of four 6.5 amp 12 Vdc nominal modules located at a distance of 40' from the batteries could have the modules wired in series, parallel or series and parallel. Input configuration possibilities in this example are 12, 24, and 48 Vdc. If the array was configured with the modules wired in parallel the input voltage would be 12 Vdc with an input current of 26 A. The same array wired in series would have an input voltage of 48 Vdc and an input current of 6.5 amps. In this example #1, the 26 amp 12 Vdc array #1/0 wire, which is prohibitively expensive, would be required to limit voltage drop to 2% which is recommended for 12 Vdc systems. The same array wired for 48 Vdc would only require a #8 wire. With the #8 wire the 12 Vdc array would have to be within 7' of the batteries. The distance that #8 cable can be used is over five times greater at 48 Vdc than 12 Vdc. (Refer to Wire Sizing Table for 2% Voltage Drop Appendix A)

Of course, a final determining factor will be the number of modules available for installation. For example the optimum system design might call for six 12 V nominal modules in series, but the actual system to be installed consists of only 10 modules. It is not possible to wire strings of differing voltages to the TurboCharger™; therefore the number of modules available must be divided into even numbers. In the example given above each string would consist of 5 modules for a nominal voltage of 60 Vdc. The above noted system could be expanded by adding one module to each string for a nominal voltage of 72 Vdc or by adding an additional string of 5 modules and maintaining the 60 Vdc nominal input voltage.

Determining Maximum Current

The TurboCharger™ is designed to handle a maximum input current of 70 amps and a maximum output current of 80 amps – both of these ratings are continuous at 45° C. The Input voltage will be higher than output voltage hence input current (amps) will be lower than output current. For example twelve 6.5 amp 12 Vdc nominal PV modules wired in series and parallel to produce 36 Vdc would equate to an input current of 26 amps – the rated current of each string times 4. (In series wiring the voltage increases and the current remains constant.) The output current of the controller will be dependent on the voltage of the battery bank. If the array in this example was connected to a 12 Vdc battery system the output current would be 78 amps. (Current in x V nom / V Bat = Current out).

When calculating the maximum input or output current, remember to add 25% to the rated current of the PV array, this is the NEC required “headroom” to account for the PV’s ability to produce more than the rated output under some conditions.

Circuit Protection

All electrical circuits require protection from over current and shorts and the TurboCharger™ is no exception. The unit should be installed with a circuit breaker or a fused disconnect on the input and output. The TurboCharger™ has a maximum current limit of 80 amps on the output. It is designed and listed to run at its maximum rating continuously. The continuous rating does not reflect the 80% derating required by the NEC for conductors, fuses, and many circuit breakers.

The NEC requires that the output conductors have an ampacity capacity of 1.25 X the rated current after all temperature and fill corrections are calculated. This means conductors must be rated to carry 100 amps. The minimum cable necessary to carry the full rated output of both the T80 and T80HV is #3AWG, corrections for conduit fill and temperature could result in a large wire size being necessary.

Since the TurboCharger™ T80HV can accept a higher PV input voltage, a high voltage circuit breaker must be used. Apollo Solar offers circuit breakers that can accept up to 250VDC.

T80 model:

In summary Apollo Solar recommends that the input breaker be 90 amps rated for 150 Vdc and the output breaker be 100 amps rated at a minimum of 80 Vdc. Apollo Solar and it’s distribution partners offer 90 and 100 amp breakers which are compatible with widely available PV system DC service entrance enclosures.

T80HV model:

In summary Apollo Solar recommends that the input breaker be 50 amps rated for 250 Vdc and the output breaker be 100 amps rated at a minimum of 80 Vdc. Apollo Solar and it’s distribution partners offer 50 and 100 amp breakers which are compatible with widely available PV system DC service entrance enclosures.

Wiring Diagram

The simplified single-line drawing below shows the appropriate location and amperage capacity rating of circuit breakers. Please note that all circuit protection devices must be installed inside UL recognized enclosures. Follow all applicable electrical codes.

Use #3 to #8 AWG wire rated for 75° C for Battery, PV and Ground connections. Torque all terminals to 50 lb-in (5.64 N-m).

The Aux Relay screw terminals accept #14 to 22 AWG wire. Torque all signal terminals to 4.4 lb-in (0.5 N-m).

Only use circuit protection equipment which is DC rated for the appropriate amperage capacity and DC voltage.

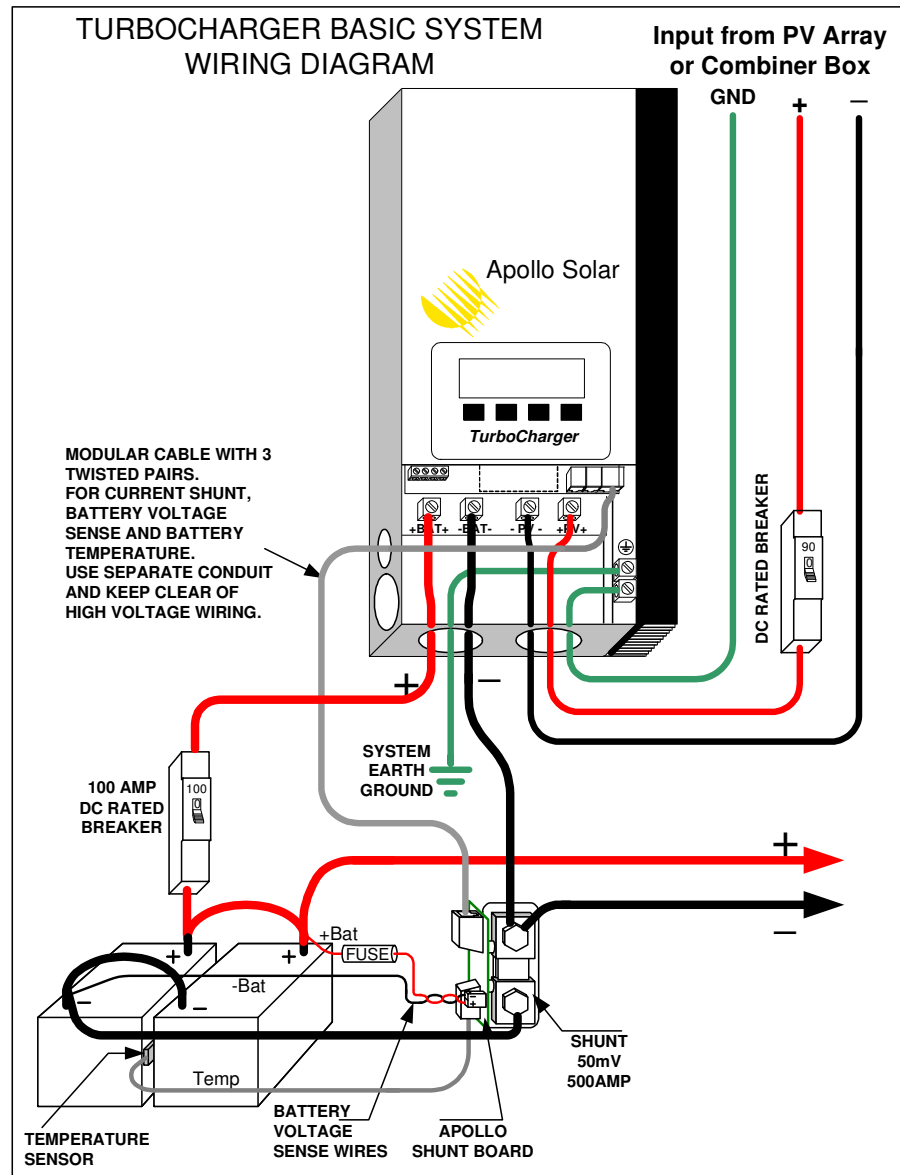

Lightning Protection

Like any other electronic device the TurboCharger™ may be damaged during lightning storms. We strongly recommend that external lightning protection devices be included as part of the circuit protection equipment.

INSTALLATION

Controller

To minimize voltage drop and keep wiring and circuit protection costs down the TurboCharger™ should be located as close to the batteries as possible while still maintaining suitable distance to prevent any risk of fire from sparks and battery gasses. The minimum distance between the TurboCharger™ and batteries should be 4' (1.2 meters).

The TurboCharger™ has one external mounting tab on top and four mounting screw locations in the wiring access area. Use #10 wood screws of sufficient length to penetrate ¾" into framing members or other solid wood materials. Screw locations are: Top Center (external) and inside wire access area. Locate the unit and install the top mounting screw first, remove wiring access cover and install the remaining mounting screws. Most installations will utilize conduit to house the wires entering and leaving TurboCharger™. The unit is designed to accept conduit between ½ and 1 ¼ inches. Follow all applicable codes and regulations during installation.

Once securely mounted with all conduit installed the unit is ready for wiring. Before attempting any wiring make sure that all disconnects (or circuit breakers) for the PV array and batteries are in the OFF position.

✎ IMPORTANT

Keep all breakers in the OFF position until ready to initiate the TurboCharger™. When you are ready to start, turn on ONLY the Battery breaker. Do NOT turn on the PV breaker until instructed during the TurboCharger™ initialization. The unit will not be damaged if the PV breaker is turned on first, but it will not operate. The internal power supply can only be powered by the batteries.

Batteries give off explosive gasses during charging. All battery enclosures should be vented to the outside. Never locate the TurboCharger™ in a poorly ventilated battery area. Do not locate the unit within 4' (1.2 meters) of the batteries.

The illustration below shows a view of the wiring access area.

There are six large lugs for the power conducting cables; Bat +, Bat -, PV -, PV + and Ground. Use #3 to #8 AWG wire rated for 75° C in each of these terminals. Torque each terminal to 50 lb-in (5.64 N-m).

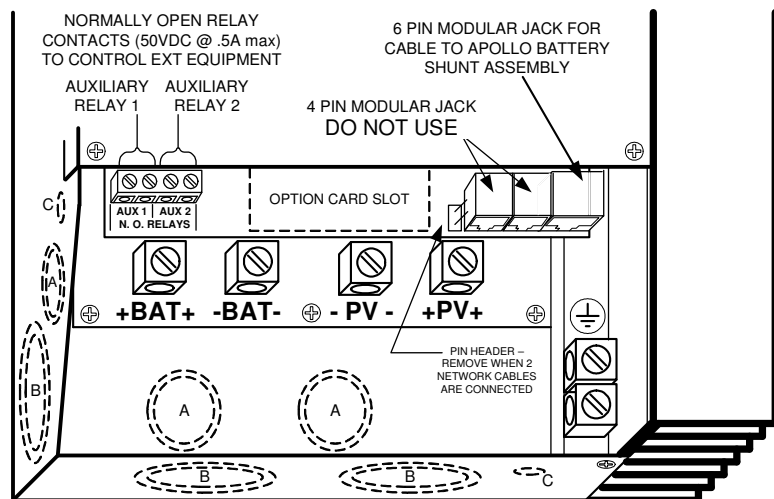

- A - KNOCK OUTS FOR 1/2" or 3/4" CONDUIT
- B - KNOCK OUTS FOR 1" or 1-1/4" CONDUIT
- C - KNOCK OUTS FOR OPTIONAL RF ANTENNA

**TURBOCHARGER WITH WIRING BOX COVER
REMOVED SHOWING CONNECTORS**

Apollo Shunt

The TurboCharger™ is designed to utilize a specially made shunt assembly. The Apollo Shunt is essential to operate at optimal levels and it serves as a hub for connecting critical measurement sensors. The main purpose of the shunt is to allow the TurboCharger™ to measure current flowing into and out of the battery. The circuit board attached to the shunt has two “modular“-type jacks (the larger jack is also known as RJ-12 and the smaller RJ-9) and one voltage sense wire jack. The modular jack marked “T80” (J3) accepts the grey cable which carries information between the shunt and the TurboCharger™. The modular jack marked “TEMP” (J5) accepts the black battery temperature sensor cable. The small white jack near the top of the T80 Shunt circuit board marked “BATT” (J4) accepts the voltage sense wires. The voltage sense wires transmit accurate battery voltage information to the TurboCharger™. Accurate voltage information is critical to perform advanced the charge control functions and for the Energy Monitor to operate properly. **Warning: The modular jacks must never be connected to telephone equipment.**

Locating the Shunt—for safety and practicality the DC load center is the recommended location for the Shunt. Most popularly available DC load centers have provisions to accept the shunt. If no load center is available or there is no room in the load center, install the shunt in a code compliant electrical enclosure.

DC Cable Installation—the shunt has two large brass bolts which thread into the top of the shunt, these are the connection location for the DC power cables. The cables which attach to the shunt should have ring terminals with a 3/8” (9.5 mm) size hole. It is very important that the shunt be installed in the correct direction. It must be installed so that the cable which connects battery negative to the shunt is connected to the shunt post marked closest to the connector labeled “BATT”.

Temperature Sensor Cable Installation—After installing the battery temperature compensation sensor (see instructions Battery Temperature Sensor on the following page) route the black cable to the Apollo Shunt and plug it into the RJ9 jack marked “TEMP”.

TurboCharger™ Cable Installation—Route this cable between the TurboCharger™ and the Apollo Shunt location. (It may be necessary to route cable through a few electrical boxes located between the shunt and controller.) **Note: This is a low voltage cable, and must not come in contact with either the battery or PV cables, nor should it be run in the same conduit.** Plug one end into the Apollo Shunt modular jack marked “T80”. When routing the cable through conduit wrap the modular plug with electrical tape to protect it from damage.

SHUNT WIRING DETAIL

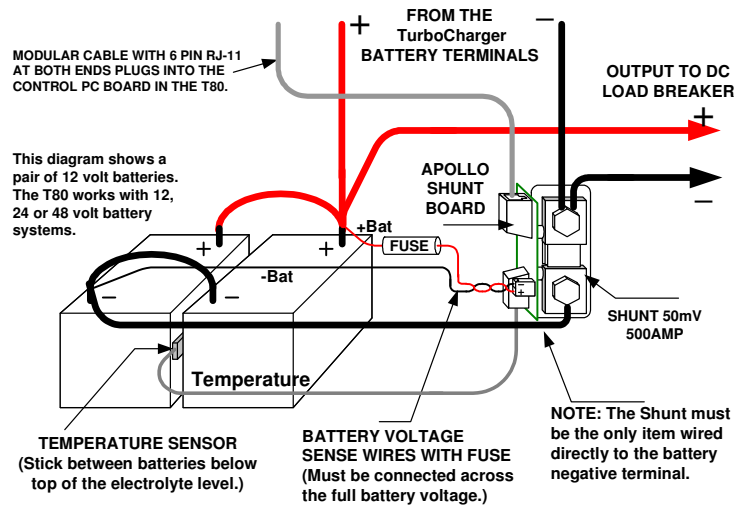

Voltage Sense Wire Installation— Push the white connector on the wire assembly onto the white connector on the Apollo Shunt circuit board after connecting the red wire to a battery positive buss and the black wire to a battery negative buss within the DC load center. Be sure to observe correct polarity when installing voltage sense wires or damage will result. Note: Fuse on positive battery terminal (1/2A 5mm x 20mm fuse).

Battery Temperature Sensor

⚠ WARNING

Batteries give off explosive gasses during charging. All battery enclosures should be vented to the outside. Never locate the TurboCharger™ in a poorly ventilated battery area. Do not locate the unit within 4' (1.2m) of batteries.

⚠ WARNING

The TurboCharger™ has an external temperature sensor which adjusts charging voltage up or down according to the temperature read by the sensor. Altering factory temperature compensation settings may result in overheated batteries which in turn could cause a fire.

The TurboCharger™ requires that the Battery Temperature Compensation Sensor (hereafter referred to as “the sensor”) be connected for all charging features to be available. The controller will operate without the sensor but the Absorption Trigger set points will be lower and equalization will be disabled.

The sensor is designed to be mounted on batteries one of two ways, onto a battery terminal or onto the side of a battery case. The method chosen will depend on the type of battery. If the battery is of single-wall construction the sensor should be located approximately half-way down the battery near the center of the battery bank. If the battery is of double-wall construction or is housed in an exterior case the sensor should be located on a battery terminal. When mounting the sensor on battery terminal be sure that the sensor is in direct contact with the terminal by installing it on the opposite side of the terminal from the DC power connection cables. Mount only on flag type terminals.

INITIALIZATION

Each TurboCharger™ requires initialization when it is first installed and commissioned. The initialization process is the way that it “gets introduced” to its new environment. A series of screens take the installer through the installation process in a simple step-by-step manner. The TurboCharger™ has a four line display which uses “soft keys” as a means of user interface. Under the display are four keys, the functions of the keys change in accordance with what is displayed above the key.

Once all mechanical and electrical connections are completed the unit is ready for commissioning. To start the initializing process, simply turn the battery breaker to the ON position. Before turning on the battery breaker please make sure that all connections are tight and secure. Make sure that the PV breaker (or other DC input source) is turned OFF. When the initialization process is complete the on screen instructions will tell the installer when to turn the PV breaker on.

Once the battery breaker is turned on a welcome screen will be displayed.

1 Welcome Screen

			A	P	O	L	L	O		S	O	L	A	R				
	T	u	r	b	o	C	h	a	r	g	e	r		T	8	0	H	V
R	E	V	:	X	.	X	X			P	:	X	X		C	:	X	X
S	/	N	:	X	X	X	X	X	X					A	S	N	E	T

The Welcome screen provides information on the model (T80 or T80HV), the numeric software revision (REV:X.XX), alphabetic hardware revision of the Power Board(P:XX) and Control Board(C:XX), serial number (S/N:XXXXXX), and option card installed (ASNET). This screen will be displayed for seven seconds while battery voltage is determined. After seven seconds the battery confirmation screen will be displayed.

2 Battery Voltage Confirmation Screen

			A	P	O	L	L	O		S	O	L	A	R				
B	A	T	T	E	R	Y		F	O	U	N	D						
			N	O	M	I	N	A	L		X	X		V	O	L	T	S
			C	O	N	F	I	R	M	:		N	O			Y	E	S

This screen displays the nominal battery voltage that the TurboCharger™ has detected and asks the installer to confirm that the voltage found is correct. In almost all circumstances the correct battery voltage will be detected. If the battery voltage displayed is different from the installed batteries immediately undertake appropriate troubleshooting procedures to ensure that the battery is wired correctly and has sufficient charge to be within its nominal voltage range.

If NO is pressed a Change Battery Voltage screen will appear.

If YES is pressed a Second Battery Voltage Confirmation screen will appear.

3 Change Battery Voltage Screen

S	E	T		B	A	T	T	E	R	Y		V	O	L	T	A	G	E	
S	C	R	O	L	L		W	I	T	H		-	O	R	+		K	E	Y
				S	E	L	E	C	T	E	D	X	X		V	O	L	T	S
								-					+			N	E	X	T

This screen will only display if NO is selected in the Confirm Voltage screen and is used to manually set nominal battery voltage. The default value displayed will be the voltage found by the TurboCharger™, selecting the – or + keys will raise or lower the battery voltage displayed in twelve volt increments.

If NEXT is selected the Second Battery Voltage Confirmation screen will appear.

4 Second Confirm Voltage Screen

B	A	T	T	E	R	Y		C	O	N	F	I	R	M	A	T	I	O	N
Y	O	U		S	E	L	E	C	T	E	D	:	X	X	V	O	L	T	S
												N	O				Y	E	S

It is critical to the safe operation of the entire electrical system that the correct battery voltage setting be entered. This screen is a safeguard and provides a second chance to review the selection and confirm it is correct.

If NO is selected the Battery Voltage Confirmation screen will appear

If YES is selected the Battery Setup screen #1 will appear.

1B Battery Setup Screen #1

B	A	T	T	E	R	Y		T	Y	P	E	=	X	X	X	X	X	X	X	
C	A	P	A	C	I	T	Y	=		X	X	X	0	A	H	R				
B	A	C	K														N	E	X	T

This screen allows the installer to “tell” the TurboCharger™ what type of batteries it is connected to (Flooded, Gel, AGM or Flooded NiCAD) and what the capacity of the batteries are.

The default “BATTERY TYPE” is GEL; choose other battery types by scrolling up or down the list. Please be sure to select the type which matches the system’s batteries. This setting controls battery charging voltages.

This setting controls battery charging amperages and other settings. The default setting for CAPACITY is 1600 amp hours. At full output capacity a TurboCharger™ can deliver 80 amps to a battery, this amount of amperage (current) is equal to the C/20 (capacity divided by twenty) rate of a 1600 amp hour battery and, as such meets most manufacturers recommendations for minimum PV charging capacity. In applications with battery banks under 1600 amp hours it is recommended to lower the Maximum Charge Rate setting from the default 80 amps to the C20 rate of the battery bank. Note: Where multiple capacities are listed in the battery manufacturer’s specifications; use the 20 Hr capacity.

The installer will be prompted to enter a capacity. Once this is entered the NEXT key will display the first in a series of Battery Setup screens. These screens offer a manual override of the default generic settings for each battery type selected. Not all setting adjustments will be available depending upon Battery Type. (For example Auto Equalization is not available for Gel batteries.).

In most cases the default settings provided for each battery type and capacity are appropriate and the installer will simply scroll through the screens confirming each setting value provided. It is not recommended to change default settings unless advised so by the battery manufacturer or supplier.

2B Battery Setup Screen #2

B	A	T	T	E	R	Y		S	E	T	U	P		2					
M	A	X		C	H	A	R	G	E		A	M	P	S	=	X	X	A	
B	A	C	K			-										N	E	X	T

This screen allows the installer to limit the maximum charge amps allowed to the batteries. The default setting is based on the Battery Capacity entered in the previous screen.

3B Battery Setup Screen #3

B	A	T	T	E	R	Y		S	E	T	U	P		3					
A	B	S	=	X	X	.	X	V		F	O	R		H	H	:	M	M	
F	L	T	=	X	X	.	X	V											
B	A	C	K			-										N	E	X	T

This screen allows the installer to adjust the Absorption and Float voltages, as well as the length of time the TurboCharger™ will charge at the Absorption voltage before switching to float mode. The default values are based on the battery type and capacity selected. It is not advisable to change default settings unless advised so by the battery manufacturer or supplier.

Note: When used in a system with a grid connected inverter. Set the sellback voltage on the inverter to just below the absorb voltage setting. This will ensure that the TurboCharger™ will deliver full current from the PV array. It is advised that sellback be turned off occasionally to allow the batteries to float.

4B Auto Equalize Screen

E	Q	U	A	L	I	Z	E		V	O	L	T	S	=	X	X	.	X	V
M	A	X		E	Q		T	I	M	E	=	H	H	:	M	M			
D	A	Y	S		B	E	T	W	E	E	N		E	Q	=	X	X	X	
B	A	C	K			-										N	E	X	T

This screen is only displayed if Flooded is selected as Battery Type. It allows the installer to override default values for equalize volts, time of equalization charge and the number of days between equalization charges. The default values are based on the battery type and capacity selected. It is not recommended to change default settings unless advised so by the battery manufacturer or supplier.

5B Set Clock Screen

S	E	T		C	L	O	C	K		M	O	D	E	=	X	X	H	r		
T	I	M	E	=	H	H	:	M	M	:	S	S	A	M						
D	A	T	E	=	M	M	/	D	D	/	Y	Y								
B	A	C	K				-				+						N	E	X	T

This screen is the final battery set up screen for all battery type and/or brand choices. It allows the installer to enter the correct time and date as well as select the time format. The installer will be prompted to select either 12 hour (AM/PM) or 24 hour clock display format. Once this selection is made the time will display 12 noon in the selected mode. Enter the correct time using the – and + keys to move the hour and minutes values up and down. Enter the correct date in the same manner.

6B Save Battery Setting Screen

			S	E	T	U	P		D	O	N	E						
D	F	L	T	=		D	E	F	A	U	L	T		V	A	L	U	E
R	C	L	L	=		R	E	C	A	L	L		L	A	S	T		
D	F	L	T		R	C	L	L		S	A	V	E					

This screen confirms that the battery settings are complete and asks the installer if they want to save the settings entered. The possible choices are DFLT (default), RCLL (recall), and SAVE.

If SAVE is selected the controller will save the entered settings and operate with them.

If DFLT is selected the controller will revert to and operate at default settings based on the original voltage, battery type and capacity entered in the initialization process. Pressing the RCLL key will return to the last settings prior to entering setup.

8B Final Battery Setup Screen

		T	U	R	N		O	N		P	V		I	N	P	U	T			
			B	R	E	A	K	E	R		N	O	W							
																	N	E	X	T

This screen confirms that the TurboCharger™ is ready to receive power from the PV array. Now is the time to turn on the breaker from the PV array. This screen will stay active until the input breaker is closed and the unit senses incoming power from the PV array. This is the end of Battery Setup, Pressing the next key will display the Main Status Screen. Please refer to the next section of this manual, “Operating the TurboCharger™” for information about Status screens.

FRONT PANEL STATUS INDICATOR LED

The Light Emitting Diode (LED) status indicator works in conjunction with the status screens. It is a three color LED (Green, Amber, Red) whose color indicates the following:

- **Steady Amber:** When the voltage from the PV array is first applied, the unit is preparing to charge.
- **Flashing Green:** The unit is in charge mode. This also serves as a “heartbeat” to indicate that the TurboCharger™ is functioning properly.
- **Alternating Green and Amber:** The unit is in equalization mode.
- **Steady Red:** Error indicator. This draws attention to error conditions displayed on the status screen:
 - High Input Voltage – Displayed if the PV voltage exceeds the maximum Input Voltage.

						E	R	R	O	R	!	!	!						
	H	I	G	H		I	N	P	U	T		V	O	L	T	A	G	E	
C	L	E	A	R															

After the error condition is corrected, pressing CLEAR will return to normal operation.

RESTARTING THE TurboCharger

From time to time there will be occasion to shut the TurboCharger™ down, which is accomplished by turning off the PV breaker and the Battery breaker thus disconnecting power. Reasons to shut down the controller include; battery or PV array maintenance, changes or additions to the system and troubleshooting. When the unit is restarted it first displays the Welcome Screen (1) for seven seconds. It then displays a screen which asks the operator to verify that the retained settings are still correct.

9B Retained Battery Setting Confirmation

B	A	T		S	E	T	U	P		X	X	V		X	X	X	X	X	H
B	E	T	T	E	R	Y		T	Y	P	E	=	X	X	X	X	X	X	X
A	B	S	=	X	X	.	X	V		F	L	T	=	X	.	X	X	V	
C	H	A	N	G	E											K	E	E	P

This screen is used when the TurboCharger™ is restarted to verify battery voltage, type, make and capacity settings. If the settings displayed are correct pressing KEEP will turn the controller on at the last retained settings. If CHANGE is selected the controller will default to Initialization Setup routine. The first screen displayed will be Battery Voltage Confirmation Screen (2).

Pressing the CHANGE key will return to the Battery Setup routine

Pressing the KEEP key will confirm the displayed settings, turn the controller on and advance to display the Set Clock screen (5B), as the clock setting is not retained when battery voltage is removed.

Note: If neither key is pressed, the unit will time out and return to the main screen, retaining the previously saved settings. In the event of a power interruption, the settings will always revert to the last retained settings.

OPERATING THE TurboCharger

STATUS SCREENS

1 Main Status Screen

Once the initial setup is complete the TurboCharger™ operates automatically and displays the Main Status Screen. This screen provides vital PV system information at a glance and provides a portal to the data reporting and custom settings features.

I	N	=	X	X	X	.	X	V		X	X	.	X	A	m	p	s	
O	U	T	=	0	X	X	.	X	V		X	X	.	X	A	m	p	s
B	A	T	S	O	C	=	X	X	X	%		X	X	X	X	X	X	X
S	E	T	U	P		S	O	C			D	A	T	A				@

The first line of the Main Status screen displays the power coming in from the PV array in Volts and Amps. The second line displays the power going out, it also displays in Volts and Amps. When no power is flowing the values will be displayed as a horizontal line.

In most installations there will be a difference between incoming volts and outgoing volts. This reflects the flexibility of the TurboCharger™ with respect to PV array input voltage vs. battery voltage. Incoming and outgoing amps will also differ because they are the result of dividing watts (a constant) by volts. (For more on this subject please see the “Planning Your System” section of this manual.)

The third line of this screen displays state of charge (SOC) as a percentage of fully charged. SOC will only be visible and active when using an optional 50mv/500amp external shunt. Following SOC% the mode that the unit is operating in is displayed. The possible values are Bulk, Absorption, Float, Man EQ, Auto EQ and Standby

Note: If the clock is not set, a clock icon will flash in the lower right corner (indicated by @ above).

Pressing the SETUP key will advance to the Setup Selections screen.

Pressing the SOC (State of Charge) key will advance to the Main Energy Monitor Screen. This key will only be active if the 50mv/500amp external shunt is installed.

Pressing the DATA key will advance to the Cumulative Data screen #1 (Energy Harvested Today)

2 Main Energy Monitor Screen

E																			F
B	A	T	T		C	U	R	R	E	N	T	=				X	X		A
X	X	X	X	X		A	H	r		I	N		B	A	T	T	E	R	Y
M	A	I	N		K	W	H	r			D	A	T	A					

The first line of the Energy Monitor screen displays State of Charge in a “Fuel Gauge” type format. If the battery has not been fully charged since power was applied, “WAITING FULL CHARGE” is displayed on the top line. The second line displays the battery current, and the third line displays the amount of charge in the battery in Ampere Hours (this can be displayed as Watt Hours as well). The third line will not be displayed if waiting for full charge.

Pressing the MAIN key will return to the Main Status screen.

Pressing the KWHR key will display KiloWatt Hours

Pressing the DATA key will advance to the Cumulative Data screen #1 (Energy Harvested Today)

DATA SCREENS

The TurboCharger™ Data screens are designed to offer the user a series of snap shots of energy harvested from the PV array. The series of screens offer scrollable; day-by-day, weekly or monthly views of energy harvest. All Cumulative Data screens automatically revert to the Cumulative Data Screen #1.0 after two minutes.

1D Cumulative Data Screen #1.0

E	N	E	R	G	Y		H	A	R	V	E	S	T		T	O	D	A	Y	
	X	X	X	X	X		K	W	H	r		X	X	X	X		A	H	r	
F	L	O	A	T		M	O	D	E	=	X	X	:	X	X					
M	A	I	N			C	L	E	A	R			S	O	C		N	E	X	T

This screen displays the solar energy harvested and how much time the charger was in Float mode “Today”. It is valuable to know that the charger enters Float mode because this is a clear indication that the batteries have been fully recharged. If the value displayed in “FLOAT MODE =” is consistently 00.00 Hr it means that the PV array is not sufficiently sized to keep up with the load. Use a generator for additional battery charging, reduce loads, or expand the PV array to ensure that batteries are fully recharged. For maximum service life batteries should be fully recharged at least once every five to ten days.

Pressing the MAIN key will return to the Main Status screen.

Pressing the SOC key will advance to the Main Energy Monitor screen.

Pressing the NEXT key will advance to the Cumulative Data screen #2

Pressing the CLEAR key will clear the Cumulative Data (see screen 4D Clear Energy Harvest)

2D Cumulative Data Screen #2.0

D	A	Y		L	O	G	#	X	X						X	X	/	X	X	
	X	X	X	X	X		K	W	H	r		X	X	X	X		A	H	r	
F	L	O	A	T		M	O	D	E	=	X	X	:	X	X					
B	A	C	K				<	<					>	>			N	E	X	T

This screen is the first of two historical power production screens. Each of them displays the energy harvested from the PV array by the unit over a period of time. When first selected the Cumulative Data screen #2 displays past power production since the last power cycle (or up to 90 days previous) along with the date of day before the current date. When the << or >> keys are selected the date scrolls backwards or forwards by one and the energy harvested on the date shown is displayed.

Pressing the BACK key will return to the Cumulative Data screen #1

Pressing the << and >> keys will toggle the date and displayed values one day forwards or backwards.

Pressing the NEXT key will advance to the Cumulative Data screen #3

3D Cumulative Data Screen #3.0

A	V	E	R	A	G	E	L	A	S	T	X	X	D	A	Y	S
X	X	X	X	X	K	W	H	r	X	X	X	X	A	H	r	
F	L	O	A	T	M	O	D	E	=	X	X	:	X	X		
B	A	C	K													

This screen shows the average power produced over the past 90 days (or since the last power cycle of the unit) displayed as both Watt Hours and Ampere Hours.

Pressing the BACK key will return to the Cumulative Data screen #2

4D Clear Energy Harvest Screen

C	L	E	A	R	E	N	E	R	G	Y	H	A	R	V	E	S	T	
T	O	D	A	Y	'	S	D	A	T	A								
L	O	G	G	E	D	D	A	T	A									
B	A	C	K							C	L	E	A	R	N	E	X	T

This screen is displayed when the CLEAR key is pressed on the Cumulative Data Screen #1. It allows the user to clear the current day's accumulated data or the logged data or both.

Pressing the NEXT key will toggle between the two selections (active selection is flashing).

Pressing CLEAR will erase the selected data.

Pressing BACK will return to Cumulative Data Screen #1.

SETUP

Although the TurboCharger™ is designed to operate automatically and does not generally require any setting alterations beyond initial set up the SETUP selections allow the installer to customize many of the operational modes and operating parameters. Pressing the SETUP key in the Main Status screen brings up the Setup Selection Screen which is the gateway to each group of settings which may be altered. Not all settings described below will appear or be available depending upon type and brand of battery selected. To take full advantage of customized settings the battery selection type should be Flooded Lead Acid and Brand should be Generic, this will make all available settings available.

Each setting selection has some common navigation features. When in the main setup screen of each feature, the final pressing of the BACK key will return to the Setup Selections screen. Pressing the BACK key in the Setup Selections screen will bring up the Main Status Screen unless any changes have been made to settings.

If any setting changes are made a Save Setup screen will become the active screen.

 **WARNING**

The TurboCharger™ is designed and intended to charge batteries of lead acid chemistry of flooded, gel and AGM construction. Altering settings for any battery type may result in improper charging and can also result batteries overheating. Do not exceed recommended minimum and maximum settings for each battery type shown below. Exceeding maximum values may cause overheated batteries and fire. Entering values lower than recommended minimums may result in improper charging and considerably shortened battery life.

The table below shows the Default, Minimum, and Maximum settings for a variety of battery types and sizes. Note: all voltage values displayed are volts per 2 volt nominal cell.

BATTERY CHARGE SETTINGS at 25 C														
DEFAULT	Voltage Values Per 2 Volt Cell				12 Volt			24 Volt			48 Volt			
	TYPE	Absorb	Float	Equalize	Absorb	Float	Equalize	Absorb	Float	Equalize	Absorb	Float	Equalize	
	Flooded	2.43	2.30	2.60		14.6	13.8	15.6	29.2	27.6	31.2	58.4	55.2	62.4
	GEL	2.35	2.25	N/A		14.1	13.5	N/A	28.2	27.0	N/A	56.4	54.0	N/A
AGM	2.35	2.20	N/A		14.1	13.2	N/A	28.2	26.4	N/A	56.4	52.8	N/A	

MINIMUM	Voltage Values Per 2 Volt Cell				12 Volt			24 Volt			48 Volt			
	TYPE	Absorb	Float	Equalize	Absorb	Float	Equalize	Absorb	Float	Equalize	Absorb	Float	Equalize	
	Flooded	2.32	2.15	2.45		13.9	12.9	14.7	27.8	25.8	29.4	55.6	51.6	58.8
	GEL	2.27	2.13	N/A		13.6	12.8	N/A	27.2	25.6	N/A	54.4	51.2	N/A
AGM	2.28	2.13	N/A		13.7	12.8	N/A	27.4	25.6	N/A	54.8	51.2	N/A	

MAXIMUM	Voltage Values Per 2 Volt Cell				12 Volt			24 Volt			48 Volt			
	TYPE	Absorb	Float	Equalize	Absorb	Float	Equalize	Absorb	Float	Equalize	Absorb	Float	Equalize	
	Flooded	2.53	2.37	2.73		15.2	14.2	16.4	30.4	28.4	32.8	60.8	56.8	65.6
	GEL	2.52	2.35	N/A		15.1	14.1	N/A	30.2	28.2	N/A	60.4	56.4	N/A
AGM	2.52	2.37	N/A		15.1	14.2	N/A	30.2	28.4	N/A	60.4	56.8	N/A	

For battery temperature other than 25° C, a correction factor of 4.0 to 5.0 mV/cell/° C should be used.

1S Setup Selections Screen

S	E	T	U	P	S	E	L	E	C	T							
B	A	T	T	E	Q	U	A	L	M	I	S	C	M	P	P	T	
A	U	X	1	A	U	X	2	E	M	O	N	I	T	O	R		
M	A	I	N					Y	E	S			N	E	X	T	

This screen allows the operator to select which type of setting to view and/or alter. The first available selection will be the Battery settings. This will be evidenced by the word BATT flashing.

Pressing the MAIN key will display the Main Status screen.

Pressing the YES key will advance to the main setup screen of the active selection.

Pressing the NEXT key will move the active selection forwards one selection. When all selections are tabbed through and CLOCK is reached pressing the NEXT key will display the Main Status screen.

Note: EQUAL will not be displayed as a choice if Gel or AGM type batteries have been selected.

1E Main EQ Setup Screen

		E	Q	U	A	L	Z	I	Z	A	T	I	O	N					
M	A	N	U	A	L		E	Q											
A	U	T	O		E	Q		I	N		#	#	#		D	A	Y	S	
B	A	C	K							Y	E	S			N	E	X	T	

This screen allows the operator to choose between manual and automatic equalization settings. The first available selection will be the MANUAL EQ settings. It also displays the days left until the next Auto Equalize if Auto Equalization is enabled.

Pressing the BACK key will move the active selection backwards one selection. When both selections are tabbed through and BACK key will display the Setup Selection screen.

Pressing the YES key will advance to the settings screen of the active selection.

Pressing the NEXT key will move the active selection forwards one selection.

2E Manual Equalization Setup Screen

		M	A	N	A	L		E	Q	U	A	L	I	Z	E				
E	Q	V	=	X	X	.	X		T	I	M	E	=	H	H	:	M	M	
C	H	E	C	K		W	A	T	E	R									
B	A	C	K			-					+				N	E	X	T	

This screen allows the operator to set the manual equalization parameters. EQ V sets the maximum equalization voltage; the default will vary according to battery bank voltage. TIME sets the length of time the equalization charge will run.

Pressing the BACK key will move the active selection backwards one selection. When both selections are tabbed through and BACK key will display the Setup Selection screen.

Pressing the NEXT key will advance to the settings screen of the active selection.

When the last active selection is reached (TIME) pressing the NEXT screen will advance to the Manual Equalization Status Screen.

Note: An error is displayed if the battery temperature sensor is not connected (see Error Screens below).

3E Manual Equalization Status Screen #1

T	I	M	E		L	E	F	T	=	H	H	:	M	M					
		B	A	T	=	X	X	.	X	V			T	=	X	X	°	C	
C	H	A	R	G	E	=	X	X	.	X	A						E	Q	
E	X	I	T												S	T	A	R	T

This screen allows the operator to start and stop the manual equalization charge after the voltage and time parameters are entered. EQ TIME LEFT displays and counts down the time remaining in the equalization charge. BAT displays battery voltage, T displays battery temperature, and CHARGE displays the charging amps. This window will remain active as long as the equalization charge is taking place.

Pressing the START key begins the equalization charge.

4E Manual Equalization Status Screen #2

T	I	M	E		L	E	F	T	=	H	H	:	M	M			H	O	T	
			B	A	T	=	X	X	.	X	V			T	=	X	X	°	C	
C	H	A	R	G	E	=	X	X	.	X	A							E	Q	
			E	Q	U	A	L	I	Z	I	N	G					S	T	O	P

This screen appears when START is pressed. HOT and EQUALIZING appear as flashing characters.

Pressing the STOP key aborts the process, and displays Manual Equalization Status Screen #1. After the equalization charge has taken place, the screen changes to the Main Status Screen.

Error Screen: Temperature Sensor Not Connected

					E	R	R	O	R	!	!	!								
	B	A	T	T	E	R	Y		T	E	M	P	E	R	A	T	U	R	E	
S	S	E	N	S	O	R		N	O	T		C	O	N	N	E	C	T	E	D
E	X	I	T																	

This screen appears when Manual Equalization is started without the temperature sensor connected. Pressing EXIT returns to the previous screen.

5E Auto Equalization Setup Screen

E	Q	U	A	L	I	Z	E		V	O	L	T	S	=	X	X	.	X	V
M	A	X		E	Q		T	I	M	E	=	H	H	:	M	M			
D	A	Y	S		B	E	T	W	E	E	N		E	Q	=	X	X	X	
B	A	C	K			-					+					N	E	X	T

This screen allows the operator to start and stop the auto equalization charge and alter the voltage, time and days between equalization parameters are entered. EQUALIZE VOLTS sets the maximum equalization voltage; the default will vary according to battery bank voltage. MAX EQ TIME sets the length of time the equalization charge will run for. DAYS BETWEEN EQ sets the number of days between equalization charges. Toggle values up and down one increment. If zero is entered, the function is disabled.

Pressing the BACK key will move the active selection backwards one selection. When both selections are tabbed through and BACK key will display the Setup Selection screen.

Pressing the NEXT key will advance to the settings screen of the active selection.

When the last active selection is reached (DAYS BETWEEN EQ) the NEXT key will become DONE, and pressing it will display the Manual Equalization Setup Screen and on will be displayed the number of days until the next Auto Equalization.

Note: If the battery temperature sensor is not connected, Auto Equalization will never start. **Check that the sensor is connected.**

6E Auto Equalization Status Screen

T	I	M	E		L	E	F	T	=	H	H	:	M	M			H	O	T	
			B	A	T	=	X	X	.	X	V			T	=	X	X	X	C	
C	H	A	R	G	E	=	X	X	.	X	A						E	Q		
			E	Q	U	A	L	I	Z	I	N	G					S	T	O	P

This screen is displayed when Auto Equalization starts. EQ TIME LEFT displays and counts down the time remaining in the equalization charge. BAT displays battery voltage and CHARGE displays the charging amps. This window will remain active as long as the equalization charge is taking place. HOT and EQUALIZING appear as flashing characters. Once the full time of the equalization charge is reached the TurboCharger™ will automatically stop the charge and the Main Status screen will display.

Pressing the STOP key will temporarily abort the process and the Main Status screen will display.

1M Main Miscellaneous Setup Screen

M	I	S	C	E	L	L	A	N	E	O	U	S		M	E	N	U		
C	L	O	C	K		B	A	C	K	L	I	G	H	T					
A	B	O	U	T		A	P	O	L	L	O		N	E	T				
B	A	C	K							Y	E	S			N	E	X	T	

This screen allows the operator to select which type of setting to view and/or alter. The first available selection will be the Clock settings. This will be evidenced by the word CLOCK flashing.

Pressing the BACK key will move the active selection backwards one selection. When all selections are tabbed through and CLOCK is reached, pressing the BACK key will display the Setup Selections Screen.

Pressing the YES key will advance to the main setup screen of the active selection.

Pressing the NEXT key will move the active selection forwards one selection. When all selections are tabbed through and ABOUT is reached pressing the NEXT key will move the active selection to CLOCK.

2M Clock Setup Screen

S	E	T		C	L	O	C	K		M	O	D	E	=	X	X	H	r		
T	I	M	E	=	H	H	:	M	M	:	S	S	A	M						
D	A	T	E	=	M	M	/	D	D	/	Y	Y								
B	A	C	K				-				+						N	E	X	T

This is the same screen as in the battery set up (Initialization section 5B on a previous page).

Note: It is important that the time and date be set properly in order for the EMONITOR to operate properly.

3M Apollo Net Setup Screen

A	P	O	L	L	O		N	E	T		S	E	T	U	P				
M	O	D	E	=						S	T	A	N	D	A	L	O	N	E
A	D	D	R	E	S	S	=		0	1									
B	A	C	K			-					+					N	E	X	T

This screen sets up the Apollo Network. Each TurboCharger™ in the network requires a mode and address entry.

The Mode choices are:

Standalone – Used when there is only one TurboCharger™ with a Remote Display connected.

Parallel Master – Used to assign the network master (this is the TurboCharger™ that connects to the shunt).

Parallel Slave – Assigns up to 15 additional TurboCharger™ slave units.

Address assigns each TurboCharger™ a unique network address (**Note: A TurboCharger™ assigned as Master or Standalone must always be address 01**). For further information on the Apollo Net, please refer to the “Networking (Stacking) Multiple T80s” section.

4M Backlight Setup Screen

T	U	R	N		O	F	F		B	A	C	K	L	I	G	H	T	:	
	A	F	T	E	R		X	X		M	I	N	U	T	E	S			
B	A	C	K			-					+								

This screen allows the operator to set the operation of the LCD backlight. Since the backlight consumes a fair amount of quiescent current, it is recommended that the on time be as short as possible. Pressing the + and – keys sets the backlight to turn off from 1 to 10 minutes in 1 minute increments.

Note: When the backlight turns off, pressing any key will turn it on without affecting the current display screen.

5M About (General Information) Screen

	T	u	r	b	o	C	h	a	r	g	e	r		T	8	0	H	V	
R	E	V	:	X	.	X	X				P	:	X	X		C	:	X	X
S	/	N	:	X	X	X	X	X	X					A	S	N	E	T	
B	A	C	K		F	A	N	*		B	O	O	T	L	O	A	D	E	R

This screen is similar to the Welcome screen which is displayed when the unit first initializes. It is useful when contacting Apollo Solar Technical Support, as it displays the firmware revision, and unit serial number. The difference is that the second key, labeled FAN, toggles the fan on and off, this allows a test as it is thermostatically controlled and not always on (the * is present when the FAN is on), and the two right keys are activated to initiate the Bootloader function. Press the BACK key to return to the main screen. **Refer to Appendix B for further information on the Bootloader function.**

There is a feature on this screen which allows the TurboCharger™ to be reset to the factory (out of box) settings. **Note: This feature should only be performed by certified installers.** To access this feature press and hold the second key from the left, and press the first (BACK) key. The following screen will appear:

			C	O	M	P	I	L	E	R		I	N	F	O				
D	A	T	E	:	O	c	t		0	5		2	0	0	7				
T	I	M	E	:	1	2	:	1	0										
B	A	C	K												F	C	T	R	Y

(Date and Time may vary)

Pressing the FCTRY key will restore the settings, and reboot the unit. Pressing the BACK key will return to the About Screen.

1P MPPT Setup Screen

M	P	P	T		S	E	T	U	P											
T	Y	P	E	=	P		&		O											
S	C	A	N		F	R	E	Q	U	E	N	C	Y	:	0	1	:	0	0	
B	A	C	K				-						+				N	E	X	T

This is the MPPT setup screen. It defaults to P&O (flashing); with a settable scan frequency of 1 minute to 4 hours (default is 1 hour). Pressing the + or – key steps through the choices of the active fields.

Pressing the BACK key will move the active selection backwards one selection (or the Setup Selections screen if on TYPE).

Pressing the NEXT key will move the active selection backwards one selection (or the Setup Selections screen if on Scan Frequency).

P&O (Perturb and Observe) will run a full scan at the set time interval (frequency) and then do P&O scans at shorter intervals in between.

If Scan and Hold is selected, the following screen is displayed:

M	P	P	T		S	E	T	U	P											
T	Y	P	E	=	S	C	A	N		A	N	D		H	O	L	D			
S	C	A	N		F	R	E	Q	U	E	N	C	Y	:	0	1	:	0	0	
B	A	C	K				-						+				N	E	X	T

Scan and Hold will run a full scan at the set time interval (frequency) and then hold the resultant MP until the next interval. This is also settable from 1 minute to 4 hours (default 1 hour).

If Percentage is selected, the following screen is displayed:

M	P	P	T		S	E	T	U	P											
T	Y	P	E	=	P	E	R	C	E	N	T	A	G	E						
0	8	0	%		V	O	C		E	V	E	R	Y	:	0	1	:	0	0	
B	A	C	K				-						+				N	E	X	T

Percentage measures the VOC at the set time interval and calculates the operating Vmp based on the percentage set. The percentage set point can be from 0 – 100% (default is 80%) and time is 1 minute to 4 hours (default is 1 hour).

If Hold Input Voltage is selected, the following screen is displayed:

M	P	P	T		S	E	T	U	P										
T	Y	P	E	=	H	O	L	D		I	N	P	U	T		V			
H	O	L	D		I	N	P	U	T		A	T		1	4	0	.0V		
B	A	C	K				-				+					N	E	X	T

Hold Input Voltage will regulate based on the input voltage set (0 – 140V), based on the panel type. The output current will be based on that voltage.

AUX1/2 Relay Setup Screen

The Auxiliary relays are useful for functions such as turning a generator on or off at low battery voltage or load change, turning on an external fan when battery temperature increases, or shedding certain loads at specific times. Additional functions will be added in the future. The settings are the same for both Aux1 and Aux2.

1A Aux 1/2 Manual (ON/OFF) Setup

R	E	L	A	Y		X		M	O	D	E	=					O	F	F	
B	A	C	K				O	N				+					D	O	N	E

This mode toggles the selected relay on or off.

Pressing the BACK key will display the Setup Selections screen.

Pressing ON will turn the relay on constant (ON is then replaced by OFF in the menu.)

The + key switches to the next Relay Setup (PV Voltage)

Pressing the DONE key will save the setting, and return to the Setup Selections screen.

2A AUX1/2 PV Voltage Setup

R	E	L	A	Y		X		M	O	D	E	=				P	V		V
O	N	<	X	X	X	.	X	V		O	F	F	>	X	X	X	.	X	V
M	I	N	.		O	N	=	H	H	:	M	M			R	L	Y	:	X
B	A	C	K				-					+				N	E	X	T

ON sets the voltage at which the relay activates. OFF sets the voltage at which the relay deactivates.

The display will change to less than or greater than (< >) depending on which voltage is higher or lower.

This allows setting on either a rising or falling voltage. MIN ON is the minimum time that the relay can remain active. RLY:X indicates whether the relay is off (X=0) or on (X=1).

Pressing the BACK key will move the active selection backwards one selection. When all selections are tabbed through and PV V is reached, pressing the BACK key will display the Setup Selections Screen.

The + and – keys will increment or decrement the value within the selected field.

Pressing the NEXT key will move the active selection forwards one selection.

3A AUX1/2 Battery Voltage Setup

R	E	L	A	Y	X	M	O	D	E	=	B	A	T	T	V			
O	N	<	X	X	X	.	X	V	O	F	F	>	X	X	X	.	X	V
M	I	N	.	O	N	=	H	H	:	M	M	R	L	Y	:	X		
B	A	C	K	-	+	N	E	X	T									

This mode activates the Aux Relay when the Battery Terminal voltage (signal from the Smart Shunt) equals the set value. ON sets the voltage at which the relay activates. OFF sets the voltage at which the relay deactivates. The display will change to less than or greater than (< >) depending on which voltage is higher or lower. This allows setting on either a rising or falling voltage. MIN ON is the minimum time that the relay can remain active. RLY:X indicates whether the relay is off (X=0) or on (X=1).

Pressing the BACK key will move the active selection backwards one selection. When all selections are tabbed through and PV V is reached, pressing the BACK key will display the Setup Selections Screen.

The + and – keys will increment or decrement the value within the selected field.

Pressing the NEXT key will move the active selection forwards one selection.

4A AUX1/2 Output Current Setup

R	E	L	A	Y	X	M	O	D	E	=	O	U	T	I		
O	N	<	X	X	X	A	O	F	F	>	X	X	X	A		
M	I	N	.	O	N	=	H	H	:	M	M	R	L	Y	:	X
B	A	C	K	-	+	N	E	X	T							

ON sets the amps at which the relay activates. OFF sets the amps at which the relay deactivates. The display will change to less than or greater than (< >) depending on which current value is higher or lower. This allows setting on either a rising or falling current. MIN ON is the minimum time that the relay can remain active.

Pressing the BACK key will move the active selection backwards one selection. When all selections are tabbed through and AMPS is reached, pressing the BACK key will display the Setup Selections Screen.

The + and – keys will increment or decrement the value within the selected field.

Pressing the NEXT key will move the active selection forwards one selection.

5A AUX1/2 Battery Current Setup

R	E	L	A	Y	X	M	O	D	E	=	B	A	T	T	I		
O	N	>	X	X	X	A		O	F	F	<	X	X	X	A		
M	I	N	.	O	N	=	H	H	:	M	M		R	L	Y	:	X
B	A	C	K			-					+		N	E	X	T	

ON sets the current at which the relay activates. OFF sets the current at which the relay deactivates. The values may be positive or negative as this input reads load current as well as charge current. The display will change to less than or greater than (< >) depending on which current value is higher or lower. This allows setting on either a rising or falling current. MIN ON is the minimum time that the relay can remain active.

Pressing the BACK key will move the active selection backwards one selection. When all selections are tabbed through and AMPS is reached, pressing the BACK key will display the Setup Selections Screen.

The + and – keys will increment or decrement the value within the selected field.

Pressing the NEXT key will move the active selection forwards one selection.

6A AUX1/2 TurboCharger™ Temperature Setup

R	E	L	A	Y	X	M	O	D	E	=	T	8	0	T			
O	N	>	X	X	X	°	C		O	F	F	<	X	X	X	°	C
M	I	N	.	O	N	=	H	H	:	M	M		R	L	Y	:	X
B	A	C	K			-					+		N	E	X	T	

ON sets the temperature at which the relay activates. OFF sets the temperature at which the relay deactivates. The display will change to less than or greater than (< >) depending on which temperature value is higher or lower. This allows setting on either a rising or falling temperature. MIN ON is the minimum time that the relay can remain active.

Pressing the BACK key will move the active selection backwards one selection. When all selections are tabbed through and TEMP is reached, pressing the BACK key will display the Setup Selections Screen.

The + and – keys will increment or decrement the value within the selected field.

Pressing the NEXT key will move the active selection forwards one selection.

7A AUX1/2 Battery Temperature Setup

R	E	L	A	Y	X	M	O	D	E	=	B	A	T	T	T	
O	N	=	X	X	X	°	C	O	F	F	=	X	X	X	°	C
M	I	N	.	O	N	=	H	H	:	M	M	R	L	Y	:	X
B	A	C	K	-	+	N	E	X	T							

ON sets the temperature at which the relay activates. OFF sets the temperature at which the relay deactivates. The display will change to less than or greater than (< >) depending on which temperature value is higher or lower. This allows setting on either a rising or falling temperature. MIN ON is the minimum time that the relay can remain active.

Pressing the BACK key will move the active selection backwards one selection. When all selections are tabbed through and TEMP is reached, pressing the BACK key will display the Setup Selections Screen.

The + and – keys will increment or decrement the value within the selected field.

Pressing the NEXT key will move the active selection forwards one selection.

8A AUX1/2 Time Setup

R	E	L	A	Y	X	M	O	D	E	=	T	I	M	E		
O	N	=	H	H	:	M	M	O	F	F	=	H	H	:	M	M
											R	L	Y	:	X	
B	A	C	K	-	+	N	E	X	T							

ON sets the time at which the relay activates. OFF sets the time at which the relay deactivates.

Pressing the BACK key will move the active selection backwards one selection. When all selections are tabbed through and TIME is reached, pressing the BACK key will display the Setup Selections screen.

The + and – keys will increment or decrement the value within the selected field.

Pressing the NEXT key will move the active selection forwards one selection.

9A AUX1/2 SOC Setup

R	E	L	A	Y	S	E	T	T	I	N	G	=	S	O	C	
O	N	=	X	X	X	%	O	F	F	=	X	X	X	%		
M	I	N	O	N	=	X	X	:	X	X	R	L	Y	=	X	
B	A	C	K	+	-	N	E	X	T							

ON sets the voltage at which the relay activates. OFF sets the voltage at which the relay deactivates. MIN ON is the minimum time that the relay can remain active.

Pressing the BACK key will move the active selection backwards one selection. When all selections are tabbed through and ON is reached, pressing the BACK key will display the Setup Selections screen.

The + and – keys will increment or decrement the value within the selected field.

Pressing the NEXT key will move the active selection forwards one selection.

10A AUX1/2 Output Voltage Setup

R	E	L	A	Y	X	M	O	D	E	=	O	U	T	V				
O	N	<	X	X	X	.	X	V	O	F	F	>	X	X	X	.	X	V
M	I	N	.	O	N	=	H	H	:	M	M	R	L	Y	:	X		
B	A	C	K	-	+	N	E	X	T									

This mode activates the Aux Relay when the voltage at the TurboCharger™ Output (to battery) terminals equals the set value. ON sets the voltage at which the relay activates. OFF sets the voltage at which the relay deactivates. The equal sign (=) will change to less than or greater than (< >) depending on which voltage is higher or lower. This allows setting on either a rising or falling voltage. MIN ON is the minimum time that the relay can remain active. RLY:X indicates whether the relay is off (X=0) or on (X=1).

Pressing the BACK key will move the active selection backwards one selection. When all selections are tabbed through and PV V is reached, pressing the BACK key will display the Setup Selections Screen.

The + and – keys will increment or decrement the value within the selected field.

Pressing the NEXT key will move the active selection forwards one selection.

1E EMONITOR Setup screen

E	N	E	R	G	Y	M	O	N	I	T	O	R	S	E	T	U	P
C	H	G	E	F	F	I	C	I	E	N	C	Y	:	X	X	X	%
-	+	D	O	N	E												

This screen allows the user to enter the Charge Efficiency factor to determine battery state of charge. If this value is not known, it is recommended that 94% be used to start. Charge efficiency is the ratio of total amp-hours out divided by total amp-hours to charge the battery.

The + and – keys will increment or decrement the value within the selected field.

Pressing DONE will display the Setup Selections Screen.

If the Batteries are at a relatively constant temperature, the ideal is that amp-hour reading is zero at the time the batteries are fully charged. If the amp-hour reading is somewhat below 0 (negative), the Efficiency can be increased. If the amp-hour reading is somewhat above zero, the Efficiency should be decreased.

Wiring Diagram with Batteries

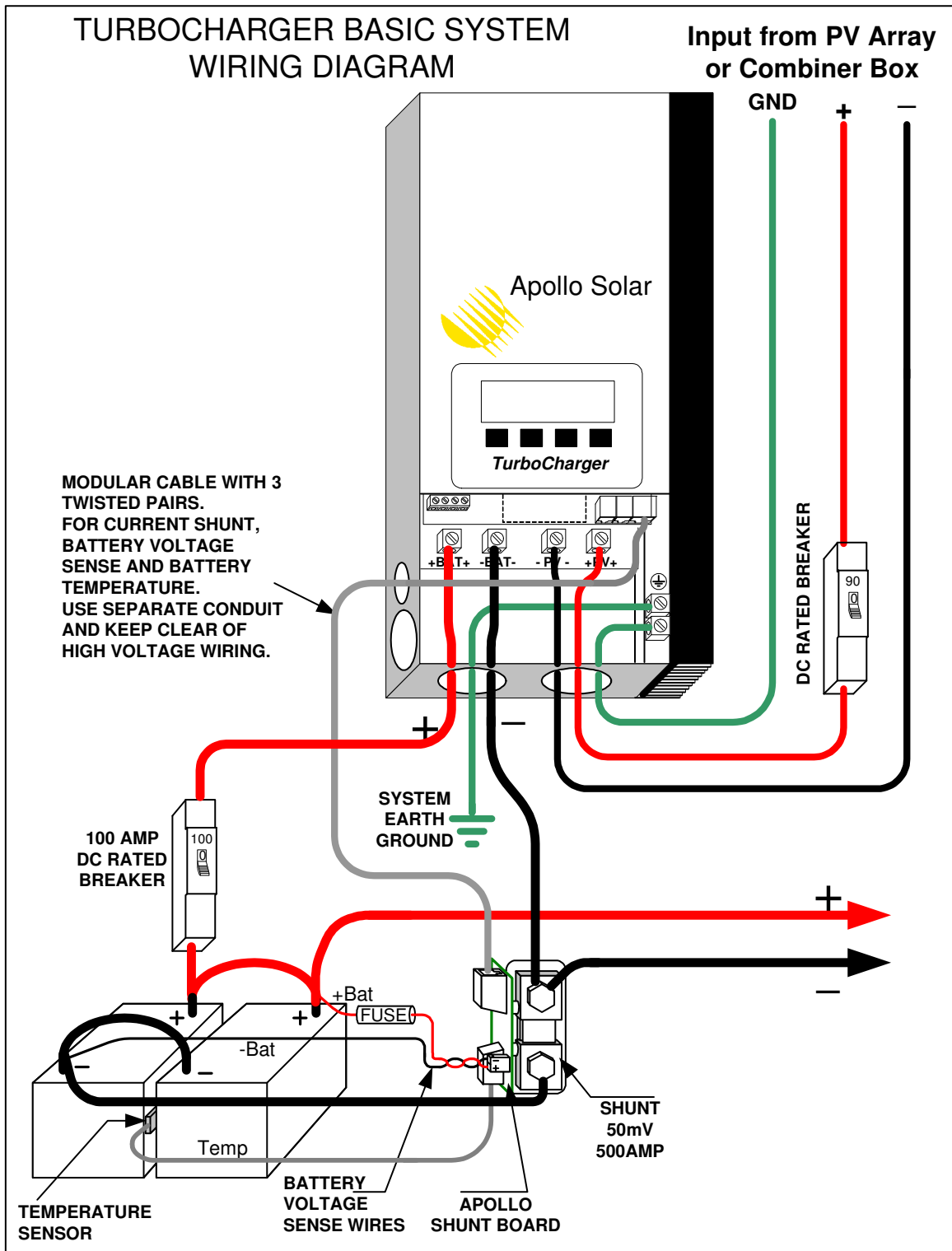

The drawing above shows a schematic of the TurboCharger™ installed in a battery system. Remember all circuit protection devices must be installed inside appropriately rated UL recognized enclosures.

Networking (Stacking) Multiple T80s

How it works

Input: Each unit operates the input side independently. That is each unit has its own PV Array and runs its own MPPT algorithm based on the conditions of that array.

Output: All the Units in the Network work together on the output side. They charge the batteries as though they are 1 large charge controller guided by the Master unit. The Master unit sends each unit the information collected from the Apollo Shunt as well as all the Battery setup information. If the Master unit is shut off all the Slave units display an error but will continue operating using the setup parameters that they last received from the master.

Installation and Setup

1. Connect the TurboCharger™ units to the battery bank and PV arrays with both the input (PV) and output (battery) breakers off. The unit with the Apollo Shunt connected to it will be the Master Unit and the others (up to 15) will be Slave Units. **Note: T80s and T80HVs may be mixed in a networked system.**

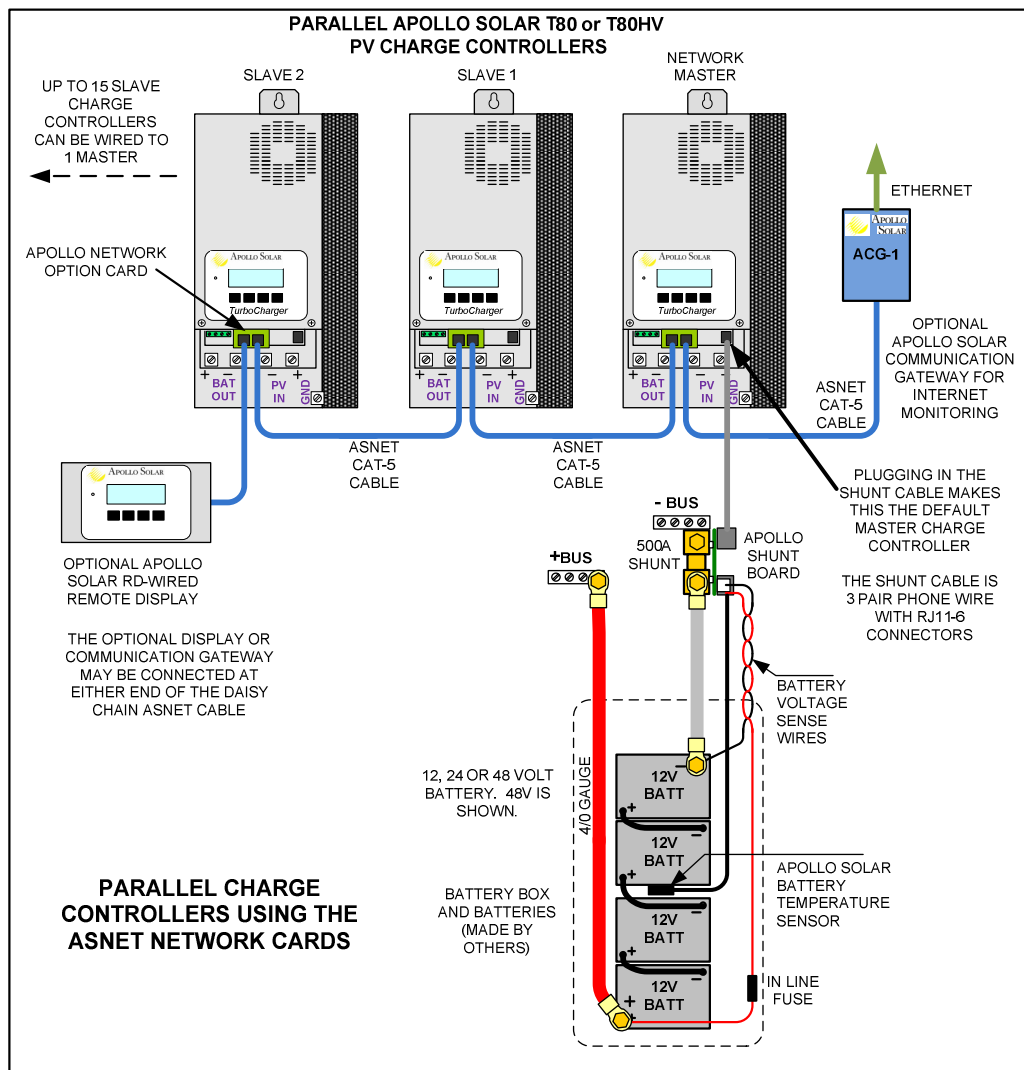

Figure 1: Network Wiring Diagram

2. Turn ON the battery breaker for the Master Unit.
3. The unit will come up with the Welcome Screen (it will not indicate a network option card unless one has been installed for a Remote Display). This screen remains for approximately 7 seconds.

				A	P	O	L	L	O		S	O	L	A	R				
		T	u	r	b	o	C	h	a	r	g	e	r		T	8	0		
R	E	V	:	X	.	X	X				P	:	X	X		C	:	X	X
S	/	N	:	X	X	X	X	X	X		A	S	N	E	T		V	2	

4. If an ASNET Card is installed the Apollo Net Setup Screen will then appear. Use the + and – buttons to set the MODE to MASTER and press DONE.

If there is no ASNET Card then the Main Status Screen will appear. Select SETUP-MISC-APOLLO NET to get to the Apollo Net Setup Screen. Use the + and – buttons to set the MODE to MASTER and press DONE.

A	P	O	L	L	O		N	E	T		S	E	T	U	P						
M	O	D	E	=	P	A	R	A	L	L	E	L		M	A	S	T	E	R		
A	D	D	R	E	S	S	=		0	1											
B	A	C	K				-							+				D	O	N	E

5. Continue to set up the Master Unit as detailed in this Manual (INITIALIZING or RESTARTING THE TurboCharger™). Stop at the following screen and proceed to step 8.

		T	U	R	N		O	N		P	V		I	N	P	U	T				
						B	R	E	A	K	E	R		N	O	W					
																		N	E	X	T

6. Turn ON the output (battery) breaker for the first Slave Unit. It doesn't matter which one.
7. The Unit will come up with the Splash screen indication that a network card is detected (as in Step 6).
8. The Apollo Net Setup Screen will then appear (as in Step 6). Use the + and – buttons to set the MODE to PARALLEL SLAVE and press NEXT.
9. Use the + and – buttons to set the ADDRESS to 02 and press DONE.
10. The Battery Setup 2 Screen will then appear and then you must enter the correct Maximum Charge Current for this unit. It will usually be based on the battery Capacity and thus the same as on the Master Unit unless smaller gauge wiring was used on this Unit.

B	A	T	T	E	R		S	E	T	U	P		2								
M	A	X		C	H	A	R	G	E		A	M	P	S	=		X	X	A		
B	A	C	K				-							+				N	E	X	T

11. The following screen will appear. Press SAVE to save the setup.

				S	E	T	U	P		D	O	N	E						
R	C	L	L	=		R	E	C	A	L	L		L	A	S	T			
						R	C	L	L			S	A	V	E				

12. Repeat steps 8-13 to for each additional slave unit selecting a different Slave Address for each.
13. After setting up all the slave units turn off the output (battery) breakers for all the units, including the master unit.
14. Turn ON the output (battery) breakers for all the units one at a time in any order.
15. On the Master Unit follow the instructions for RESTARTING THE TurboCharger™ in this manual.
16. On each Slave Unit the Following Screen will appear after the Splash screen (Step 5). Press The KEEP button unless the Current is incorrect or the system parameters have changed.

B	A	T	T	E	R	Y		S	E	T	U	P		2						
M	A	X		C	H	A	R	G	E		A	M	P	S	=	X	X	A		
C	H	A	N	G	E												K	E	E	P

17. The following screen will appear. Press SAVE to save the setup.

				S	E	T	U	P		D	O	N	E						
R	C	L	L	=		R	E	C	A	L	L		L	A	S	T			
						R	C	L	L			S	A	V	E				

18. The following screen will appear. Press the NEXT Button and then turn ON all the PV breakers and you are charging batteries.

		T	U	R	N		O	N		P	V		I	N	P	U	T			
						B	R	E	A	K	E	R		N	O	W				
																	N	E	X	T

Modifying the Network

If you want to modify the network settings go into the SETUP screen and select MISC. Then select APOLLO NET and the APOLLO NET SETUP Screen will appear (Step 6 above). After the any changes all the units in the system must be shut down and restarted.

Five Year Limited Warranty Information

Warranty and Conditions

Apollo Solar Inc. warrants that the TurboCharger™ it manufacturers will be free from defects in materials and workmanship for a period of five (5) years subject to the conditions set forth below:

- ⇒ This limited warranty is extended to the original user and is non-transferable.
- ⇒ The limited warranty term begins on the date of invoice to the original user of the product. If no invoice is available the warranty term begins on the date of manufacture as recorded by the serial number of the unit.
- ⇒ The limited warranty does NOT apply to any product or part thereof damaged or made inoperable by:
 - Operation or installation contrary to the TurboCharger™ manual, alteration or disassembly, reverse polarity, accident or abuse, corrosion,
 - lightning damage, or repair or service provided by an unauthorized repair facility.

Apollo Solar's liability for any defective TurboCharger™ or any part thereof shall be limited to the repair or replacement of the TurboCharger™, at Apollo Solar's discretion. This warranty is limited to the TurboCharger™ and in no way extends to cover the workmanship of any individual or firm installing the product.

How to Get Warranty Service

This warranty requires that all equipment suspected of being defective in either materials or workmanship be returned to Apollo Solar or its designated service agents. During the five year warranty period products covered under this warranty will be repaired or replaced with equivalent equipment at the discretion of Apollo Solar.

- ⇒ All products submitted for warranty service must have an RMA number.

To obtain an RMA (return merchandise approval) number, a return shipping address and/or more information about your limited warranty contact Apollo Solar by phone 203 790 6400 or by email at techsupport@apollosolar.com

- ⇒ Mark all parcels sent for service with RMA number.

Send all equipment approved for warranty service in original or equivalent packaging. All inbound freight must be fully pre-paid, no items will be accepted for service with collect or COD freight charges.

Replaced or repaired equipment will be shipped to the address associated with the RMA number. Freight charges for ground service will be paid by Apollo Solar within the continental United States. Return shipments to other states or US territories or foreign countries will be sent freight collect.

THIS LIMITED WARRANTY GIVES YOU SPECIFIC LEGAL RIGHTS, AND YOU MAY ALSO HAVE OTHER RIGHTS THAT VARY FROM STATE TO STATE (OR JURISDICTION TO JURISDICTION). APOLLO SOLAR'S RESPONSIBILITY FOR MALFUNCTIONS AND DEFECTS IN HARDWARE IS LIMITED TO REPAIR AND REPLACEMENT AS SET FORTH IN THIS LIMITED WARRANTY STATEMENT. ALL EXPRESS AND IMPLIED WARRANTIES FOR THE PRODUCT, INCLUDING BUT NOT LIMITED TO ANY IMPLIED WARRANTIES OF AND CONDITIONS OF MERCHANTABILITY AND FITNESS FOR PARTICULAR PURPOSE, ARE LIMITED IN DURATION TO THE LIMITED WARRANTY PERIOD SET FORTH ABOVE AND NO WARRANTIES, WHETHER EXPRESS OR IMPLIED, WILL APPLY AFTER SUCH PERIOD. SOME STATES (OR JURISDICTIONS) DO NOT ALLOW LIMITATIONS ON HOW LONG IMPLIED WARRANTY LASTS, SO THE ABOVE LIMITATION MAY NOT APPLY TO YOU. APOLLO SOLAR DOES NOT ACCEPT LIABILITY BEYOND THE REMEDIES SET FORTH IN THIS LIMITED WARRANTY STATEMENT OR LIABILITY FOR INCIDENTAL OR CONSEQUENTIAL DAMAGES, INCLUDING WITHOUT LIMITATION ANY LIABILITY FOR PRODUCTS NOT BEING AVAILABLE FOR USE. SOME STATES (OR JURISDICTIONS) DO NOT ALLOW THE EXCLUSION OR LIMITATION OF INCIDENTAL OR CONSEQUENTIAL DAMAGES, SO THE ABOVE EXCLUSION OR LIMITATION MAY NOT APPLY TO YOU.

Appendix A

Wire Sizing Table for 1.5% Voltage Drop

The following chart provides the maximum distance from the PV array to the Apollo Solar T80HV Charge Controller. The chart assumes 2 conductor copper wire and allows for a 1.5% voltage drop. The figures are based on ASTM Specification B3-63.

WIRE DISTANCE CHART - LENGTH OF WIRE PAIR IN FEET FROM PV ARRAY TO THE T80HV CHARGE CONTROLLER

"12 volt" PV array Actually 16 Vmp	PV = 12 Volts	WIRE GAUGE FROM PV ARRAY TO APOLLO SOLAR T80						
	PV Amps	#8	#6	#4	#2	#1/0	#2/0	#4/0
	10	18.1	28.9	45.9	72.9	116.0	146.3	228.0
Use for 12 volt battery systems	20	9.1	14.4	22.9	36.5	58.0	73.2	114.0
	30	6.0	9.6	15.3	24.3	38.7	48.8	76.0
	40	4.5	7.2	11.5	18.2	29.0	36.6	57.0
	50	3.6	5.8	9.2	14.6	23.2	29.3	45.6
IN FEET	60	3.0	4.8	7.6	12.2	19.3	24.4	38.0
	70	2.6	4.1	6.6	10.4	16.6	20.9	32.6

"24 volt" PV array Actually 32 Vmp	PV = 24 Volts	WIRE GAUGE FROM PV ARRAY TO APOLLO SOLAR T80						
	PV Amps	#8	#6	#4	#2	#1/0	#2/0	#4/0
	10	36.3	57.7	91.8	145.9	231.9	292.7	456.0
Use for 12, or 24 volt battery systems	20	18.1	28.9	45.9	72.9	116.0	146.3	228.0
	30	12.1	19.2	30.6	48.6	77.3	97.6	152.0
	40	9.1	14.4	22.9	36.5	58.0	73.2	114.0
	50	7.3	11.5	18.4	29.2	46.4	58.5	91.2
IN FEET	60	6.0	9.6	15.3	24.3	38.7	48.8	76.0
	70	5.2	8.2	13.1	20.8	33.1	41.8	65.1

"36 volt" PV array Actually 48 Vmp	PV = 36 Volts	WIRE GAUGE FROM PV ARRAY TO APOLLO SOLAR T80						
	PV Amps	#8	#6	#4	#2	#1/0	#2/0	#4/0
	10	54.4	86.6	137.6	218.8	347.9	439.0	684.0
Use for 12, 24 or 36 volt battery systems	20	27.2	43.3	68.8	109.4	174.0	219.5	342.0
	30	18.1	28.9	45.9	72.9	116.0	146.3	228.0
	40	13.6	21.6	34.4	54.7	87.0	109.8	171.0
	50	10.9	17.3	27.5	43.8	69.6	87.8	136.8
IN FEET	60	9.1	14.4	22.9	36.5	58.0	73.2	114.0
	70	7.8	12.4	19.7	31.3	49.7	62.7	97.7

"48 volt" PV array Actually 64 Vmp	PV = 48 Volts	WIRE GAUGE FROM PV ARRAY TO APOLLO SOLAR T80						
	PV Amps	#8	#6	#4	#2	#1/0	#2/0	#4/0
	10	72.6	115.4	183.5	291.7	463.9	585.4	912.0
Use for 12, 24, 36 or 48 volt battery systems	20	36.3	57.7	91.8	145.9	231.9	292.7	456.0
	30	24.2	38.5	61.2	97.2	154.6	195.1	304.0
	40	18.1	28.9	45.9	72.9	116.0	146.3	228.0
	50	14.5	23.1	36.7	58.3	92.8	117.1	182.4
IN FEET	60	12.1	19.2	30.6	48.6	77.3	97.6	152.0
	70	10.4	16.5	26.2	41.7	66.3	83.6	130.3

"60 volt" PV array Actually 80 Vmp	PV = 60 Volts	WIRE GAUGE FROM PV ARRAY TO APOLLO SOLAR T80						
	PV Amps	#8	#6	#4	#2	#1/0	#2/0	#4/0
	10	90.7	144.3	229.4	364.7	579.9	731.7	1140.0
Use for 12, 24, 36 or 48 volt battery systems	20	45.4	72.1	114.7	182.3	289.9	365.9	570.0
	30	30.2	48.1	76.5	121.6	193.3	243.9	380.0
	40	22.7	36.1	57.3	91.2	145.0	182.9	285.0
	50	18.1	28.9	45.9	72.9	116.0	146.3	228.0
IN FEET	60	15.1	24.0	38.2	60.8	96.6	122.0	190.0
	70	13.0	20.6	32.8	52.1	82.8	104.5	162.9

"72 volt" PV array
Actually 96 Vmp

PV Amps	WIRE GAUGE FROM PV ARRAY TO APOLLO SOLAR T80							
	#8	#6	#4	#2	#1/0	#2/0	#4/0	
10	108.9	173.1	275.3	437.6	695.8	878.0	1368.0	
20	54.4	86.6	137.6	218.8	347.9	439.0	684.0	
30	36.3	57.7	91.8	145.9	231.9	292.7	456.0	
40	27.2	43.3	68.8	109.4	174.0	219.5	342.0	
50	21.8	34.6	55.1	87.5	139.2	175.6	273.6	
60	18.1	28.9	45.9	72.9	116.0	146.3	228.0	

Use for 12, 24, 36 or 48 volt battery systems

IN FEET

"84 volt" PV array
Actually 112 Vmp

PV Amps	WIRE GAUGE FROM PV ARRAY TO APOLLO SOLAR T80							
	#8	#6	#4	#2	#1/0	#2/0	#4/0	
10	127.0	202.0	321.1	510.6	811.8	1024.4	1596.0	
20	63.5	101.0	160.6	255.3	405.9	512.2	798.0	
30	42.3	67.3	107.0	170.2	270.6	341.5	532.0	
40	31.8	50.5	80.3	127.6	203.0	256.1	399.0	
50	25.4	40.4	64.2	102.1	162.4	204.9	319.2	

Use for 12, 24, 36 or 48 volt battery systems

IN FEET

"96 volt" PV array
Actually 128 Vmp

PV Amps	WIRE GAUGE FROM PV ARRAY TO APOLLO SOLAR T80							
	#8	#6	#4	#2	#1/0	#2/0	#4/0	
10	145.2	230.8	367.0	583.5	927.8	1170.7	1824.0	
20	72.6	115.4	183.5	291.7	463.9	585.4	912.0	
30	48.4	76.9	122.3	194.5	309.3	390.2	608.0	
40	36.3	57.7	91.8	145.9	231.9	292.7	456.0	
50	29.0	46.2	73.4	116.7	185.6	234.1	364.8	

Use for 12, 24, 36 or 48 volt battery systems

IN FEET

"108 volt" PV array
Actually 144 Vmp

PV Amps	WIRE GAUGE FROM PV ARRAY TO APOLLO SOLAR T80							
	#8	#6	#4	#2	#1/0	#2/0	#4/0	
10	163.3	259.7	412.9	656.4	1043.7	1317.1	2052.0	
20	81.7	129.8	206.4	328.2	521.9	658.5	1026.0	
30	54.4	86.6	137.6	218.8	347.9	439.0	684.0	
40	40.8	64.9	103.2	164.1	260.9	329.3	513.0	
50	32.7	51.9	82.6	131.3	208.7	263.4	410.4	

Use for 12, 24, 36 or 48 volt battery systems

IN FEET

"120 volt" PV array
Actually 160 Vmp

PV Amps	WIRE GAUGE FROM PV ARRAY TO APOLLO SOLAR T80							
	#8	#6	#4	#2	#1/0	#2/0	#4/0	
10	181.5	288.5	458.8	729.4	1159.7	1463.4	2280.0	
20	90.7	144.3	229.4	364.7	579.9	731.7	1140.0	
30	60.5	96.2	152.9	243.1	386.6	487.8	760.0	
40	45.4	72.1	114.7	182.3	289.9	365.9	570.0	
50	36.3	57.7	91.8	145.9	231.9	292.7	456.0	

Use for 12, 24, 36 or 48 volt battery systems

IN FEET

**WIRE DISTANCE CHART -- IN METERS MAXIMUM VOLTAGE DROP = 1.50%
LENGTH OF WIRE PAIR IN METERS FROM PV ARRAY TO THE T80HV CHARGE CONTROLLER**

"12 volt" PV array Actually 16 Vmp	PV = 12 Volts	WIRE GAUGE FROM PV ARRAY TO APOLLO SOLAR T80						
	PV Amps	#8	#6	#4	#2	#1/0	#2/0	#4/0
Use for 12 volt battery systems IN METERS	10	5.5	8.8	14.0	22.2	35.4	44.6	70.9
	20	2.8	4.4	7.0	11.1	17.7	22.3	35.5
	30	1.8	2.9	4.7	7.4	11.8	14.9	23.6
	40	1.4	2.2	3.5	5.6	8.8	11.2	17.7
	50	1.1	1.8	2.8	4.4	7.1	8.9	14.2
	60	0.9	1.5	2.3	3.7	5.9	7.4	11.8
	70	0.8	1.3	2.0	3.2	5.1	6.4	10.1

"24 volt" PV array Actually 32 Vmp	PV = 24 Volts	WIRE GAUGE FROM PV ARRAY TO APOLLO SOLAR T80						
	PV Amps	#8	#6	#4	#2	#1/0	#2/0	#4/0
Use for 12, or 24 volt battery systems IN METERS	10	11.1	17.6	28.0	44.5	70.7	89.2	141.9
	20	5.5	8.8	14.0	22.2	35.4	44.6	70.9
	30	3.7	5.9	9.3	14.8	23.6	29.7	47.3
	40	2.8	4.4	7.0	11.1	17.7	22.3	35.5
	50	2.2	3.5	5.6	8.9	14.1	17.8	28.4
	60	1.8	2.9	4.7	7.4	11.8	14.9	23.6
	70	1.6	2.5	4.0	6.4	10.1	12.7	20.3

"36 volt" PV array Actually 48 Vmp	PV = 36 Volts	WIRE GAUGE FROM PV ARRAY TO APOLLO SOLAR T80						
	PV Amps	#8	#6	#4	#2	#1/0	#2/0	#4/0
Use for 12, 24 or 36 volt battery systems IN METERS	10	16.6	26.4	42.0	66.7	106.1	133.9	212.8
	20	8.3	13.2	21.0	33.4	53.0	66.9	106.4
	30	5.5	8.8	14.0	22.2	35.4	44.6	70.9
	40	4.1	6.6	10.5	16.7	26.5	33.5	53.2
	50	3.3	5.3	8.4	13.3	21.2	26.8	42.6
	60	2.8	4.4	7.0	11.1	17.7	22.3	35.5
	70	2.4	3.8	6.0	9.5	15.2	19.1	30.4

"48 volt" PV array Actually 64 Vmp	PV = 48 Volts	WIRE GAUGE FROM PV ARRAY TO APOLLO SOLAR T80						
	PV Amps	#8	#6	#4	#2	#1/0	#2/0	#4/0
Use for 12, 24, 36 or 48 volt battery systems IN METERS	10	22.1	35.2	55.9	88.9	141.4	178.5	283.8
	20	11.1	17.6	28.0	44.5	70.7	89.2	141.9
	30	7.4	11.7	18.6	29.6	47.1	59.5	94.6
	40	5.5	8.8	14.0	22.2	35.4	44.6	70.9
	50	4.4	7.0	11.2	17.8	28.3	35.7	56.8
	60	3.7	5.9	9.3	14.8	23.6	29.7	47.3
	70	3.2	5.0	8.0	12.7	20.2	25.5	40.5

"60 volt" PV array Actually 80 Vmp	PV = 60 Volts	WIRE GAUGE FROM PV ARRAY TO APOLLO SOLAR T80						
	PV Amps	#8	#6	#4	#2	#1/0	#2/0	#4/0
Use for 12, 24, 36 or 48 volt battery systems IN METERS	10	27.7	44.0	69.9	111.2	176.8	223.1	354.7
	20	13.8	22.0	35.0	55.6	88.4	111.5	177.3
	30	9.2	14.7	23.3	37.1	58.9	74.4	118.2
	40	6.9	11.0	17.5	27.8	44.2	55.8	88.7
	50	5.5	8.8	14.0	22.2	35.4	44.6	70.9
	60	4.6	7.3	11.7	18.5	29.5	37.2	59.1
	70	4.0	6.3	10.0	15.9	25.3	31.9	50.7

The following chart provides the maximum distance from the Apollo Solar T80HV Charge Controller to the batteries.

WIRE DISTANCE CHART - IN FEET MAXIMUM VOLTAGE DROP = 1.43%
LENGTH OF WIRE PAIR IN FEET FROM T80HV CHARGE CONTROLLER TO BATTERY

IN FEET	12 VOLT BATT WIRE GAUGE FROM APOLLO SOLAR T80 TO BATTERY							
	T80 AMPS	#8	#6	#4	#2	#1/0	#2/0	#4/0
Use for 12 volt battery systems	10	13.6	21.6	34.4	54.7	87.0	109.8	171.0
	20	6.8	10.8	17.2	27.4	43.5	54.9	85.5
	30	4.5	7.2	11.5	18.2	29.0	36.6	57.0
	40	3.4	5.4	8.6	13.7	21.7	27.4	42.8
	50	2.7	4.3	6.9	10.9	17.4	22.0	34.2
	60	2.3	3.6	5.7	9.1	14.5	18.3	28.5
	70	1.9	3.1	4.9	7.8	12.4	15.7	24.4
	80	1.7	2.7	4.3	6.8	10.9	13.7	21.4

IN FEET	24 VOLT BATT WIRE GAUGE FROM APOLLO SOLAR T80 TO BATTERY							
	T80 AMPS	#8	#6	#4	#2	#1/0	#2/0	#4/0
Use for 24 volt battery systems	10	27.2	43.3	68.8	109.4	174.0	219.5	342.0
	20	13.6	21.6	34.4	54.7	87.0	109.8	171.0
	30	9.1	14.4	22.9	36.5	58.0	73.2	114.0
	40	6.8	10.8	17.2	27.4	43.5	54.9	85.5
	50	5.4	8.7	13.8	21.9	34.8	43.9	68.4
	60	4.5	7.2	11.5	18.2	29.0	36.6	57.0
	70	3.9	6.2	9.8	15.6	24.9	31.4	48.9
	80	3.4	5.4	8.6	13.7	21.7	27.4	42.8

IN FEET	48 VOLT BATT WIRE GAUGE FROM APOLLO SOLAR T80 TO BATTERY							
	T80 AMPS	#8	#6	#4	#2	#1/0	#2/0	#4/0
Use for 48 volt battery systems	10	54.4	86.6	137.6	218.8	347.9	439.0	684.0
	20	27.2	43.3	68.8	109.4	174.0	219.5	342.0
	30	18.1	28.9	45.9	72.9	116.0	146.3	228.0
	40	13.6	21.6	34.4	54.7	87.0	109.8	171.0
	50	10.9	17.3	27.5	43.8	69.6	87.8	136.8
	60	9.1	14.4	22.9	36.5	58.0	73.2	114.0
	70	7.8	12.4	19.7	31.3	49.7	62.7	97.7
	80	6.8	10.8	17.2	27.4	43.5	54.9	85.5

**WIRE DISTANCE CHART - IN METERS MAXIMUM VOLTAGE DROP = 1.43%
 LENGTH OF WIRE PAIR IN METERS FROM T80HV CHARGE CONTROLLER TO BATTERY**

IN METERS	12 VOLT BATT	WIRE GAUGE FROM APOLLO SOLAR T80 TO BATTERY						
	T80 AMPS	#8	#6	#4	#2	#1/0	#2/0	#4/0
Use for 12 volt battery systems	10	4.1	6.6	10.5	16.7	26.5	33.5	53.2
	20	2.1	3.3	5.2	8.3	13.3	16.7	26.6
	30	1.4	2.2	3.5	5.6	8.8	11.2	17.7
	40	1.0	1.6	2.6	4.2	6.6	8.4	13.3
	50	0.8	1.3	2.1	3.3	5.3	6.7	10.6
	60	0.7	1.1	1.7	2.8	4.4	5.6	8.9
	70	0.6	0.9	1.5	2.4	3.8	4.8	7.6
	80	0.5	0.8	1.3	2.1	3.3	4.2	6.7

IN METERS	24 VOLT BATT	WIRE GAUGE FROM APOLLO SOLAR T80 TO BATTERY						
	T80 AMPS	#8	#6	#4	#2	#1/0	#2/0	#4/0
Use for 24 volt battery systems	10	8.3	13.2	21.0	33.4	53.0	66.9	106.4
	20	4.1	6.6	10.5	16.7	26.5	33.5	53.2
	30	2.8	4.4	7.0	11.1	17.7	22.3	35.5
	40	2.1	3.3	5.2	8.3	13.3	16.7	26.6
	50	1.7	2.6	4.2	6.7	10.6	13.4	21.3
	60	1.4	2.2	3.5	5.6	8.8	11.2	17.7
	70	1.2	1.9	3.0	4.8	7.6	9.6	15.2
	80	1.0	1.6	2.6	4.2	6.6	8.4	13.3

IN METERS	48 VOLT BATT	WIRE GAUGE FROM APOLLO SOLAR T80 TO BATTERY						
	T80 AMPS	#8	#6	#4	#2	#1/0	#2/0	#4/0
Use for 48 volt battery systems	10	16.6	26.4	42.0	66.7	106.1	133.9	212.8
	20	8.3	13.2	21.0	33.4	53.0	66.9	106.4
	30	5.5	8.8	14.0	22.2	35.4	44.6	70.9
	40	4.1	6.6	10.5	16.7	26.5	33.5	53.2
	50	3.3	5.3	8.4	13.3	21.2	26.8	42.6
	60	2.8	4.4	7.0	11.1	17.7	22.3	35.5
	70	2.4	3.8	6.0	9.5	15.2	19.1	30.4
	80	2.1	3.3	5.2	8.3	13.3	16.7	26.6

Appendix B

Bootloader Function

As of software revision 5.00, a new bootloader function has been added. This allows updating operating firmware via a Remote Display and SD memory card. It is accessed via the ABOUT screen in the Miscellaneous Menu.

WARNING

This function should be entered only if a Remote Display is connected and set up for downloading firmware changes.

5M About (General Information) Screen

	T	u	r	b	o	C	h	a	r	g	e	r		T	8	0	H	V	
R	E	V	:	X	.	X	X			P	:	X	X		C	:	X	X	
S	/	N	:	X	X	X	X	X	X					A	S	N	E	T	
B	A	C	K							B	O	O	T	L	O	A	D	E	R

This is the screen is similar to the Welcome screen which is displayed when the unit first initializes. It is useful when contacting Apollo Solar Technical Support, as it displays the firmware revision, and unit serial number. The difference is that the two right keys are activated to initiate the Bootloader function. Press the BACK key to return to the main screen.

6M Bootloader Entry Screen

				W	A	R	N	I	N	G	!	!	!						
		R	E	A	D		M	A	N	U	A	L		F	I	R	S	T	
L	O	A	D		N	E	W		S	O	F	T	W	A	R	E			
B	A	C	K													Y	E	S	

This is the Bootloader initiation screen. It is only used to update T80HV firmware.

Pressing the BACK key returns to the previous screen

Pressing the YES key continues the Bootloading process.

IMPORTANT

PLEASE REFER TO THE REMOTE DISPLAY USER MANUAL FOR FULL INSTRUCTIONS!